

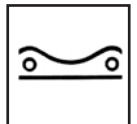

## Netter Fastening Sets for PKL Series NBS



- Safe and solid attachment of the PKL impactors
- Versions for threaded or clearance bores



NBS 740 for PKL 740



NBS 2100 for PKL 2100  
or NBS 5000 for PKL 5000



**NetterVibration**



## Netter Fastening Set for PKL Series NBS

Impactor Type	NBS Type	Fastening screws	Fastening plates thickness [mm]
PKL 740	NBS 740		
PKL 740	NBS G 740	M12x60	15
PKL 740	NBS D 740	M12x90	15
PKL 2100	NBS 2100		
PKL 2100	NBS G 2100	M12x50	15
PKL 2100	NBS D 2100	M12x90	15
PKL 5000	NBS 5000		
PKL 5000	NBS G 5000	M16x75	20
PKL 5000	NBS D 5000	M16x110	20

### Mounting procedure using the example of the NBS 740 D on a PKL 740

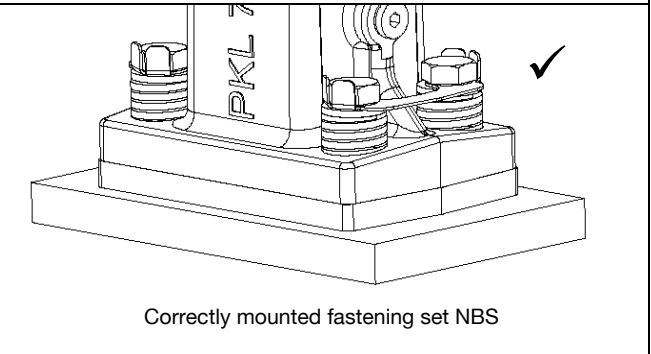
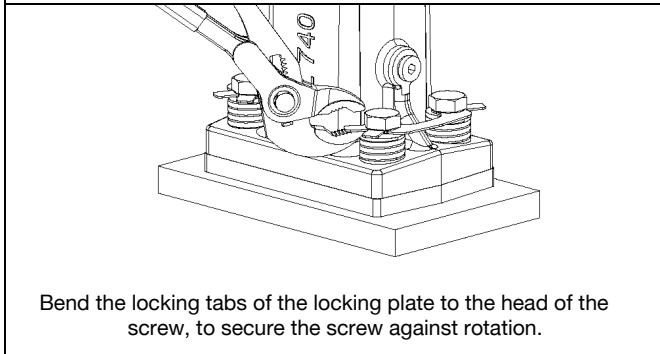
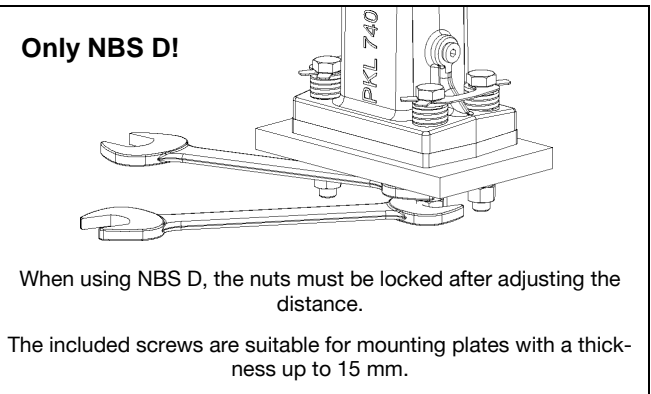
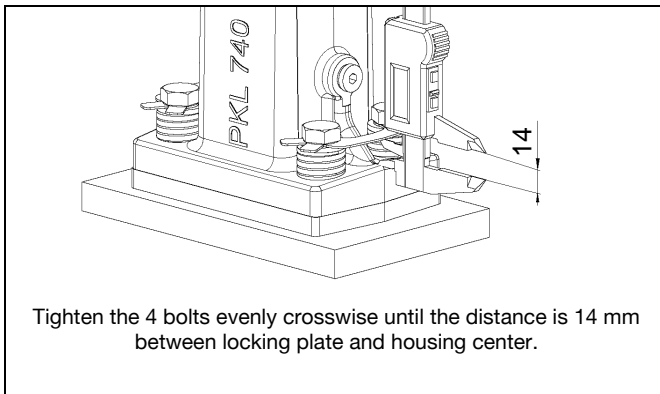

#### Applications:

The NBS fixing sets provide a safe and solid attachment of the PKL impactors.

**NetterVibration** provides on request, these NBS fixing sets (screws, springs, matching washers).

**NetterVibration** offers the accessories required for the mounting, installation, control and monitoring of vibrators and impactors.

**Netter provides solutions.**  
Consult our experienced application technicians.

#### Netter GmbH

Fritz-Lenges-Str. 3  
55252 Mainz-Kastel

- Germany
- Switzerland
- Poland
- Spain
- Australia

www.**NetterVibration**.com  
info@**NetterVibration**.com