

49

Hydraulic Vibrating Unit Series NHW

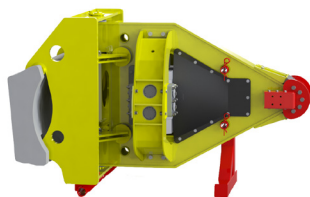

- Mobile wagon emptying device
- Quick-change connector for any carrier (e.g. wheel loader)
- Drive via the on-board hydraulic system with adjustable impact frequency



NHW with quick-change connector

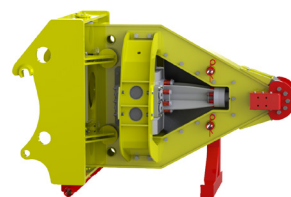

NHW without protective cover



Hydraulic Vibrating Unit Series NHW

Type	Working torque [cmkg]	Frequency [min-1]	Centrifugal force [N]	Oil requirement [l/min]	Noise level [db(A)]	Weight [kg]
NHW	219	3,000	up to 108,066	48	> 80	1,800

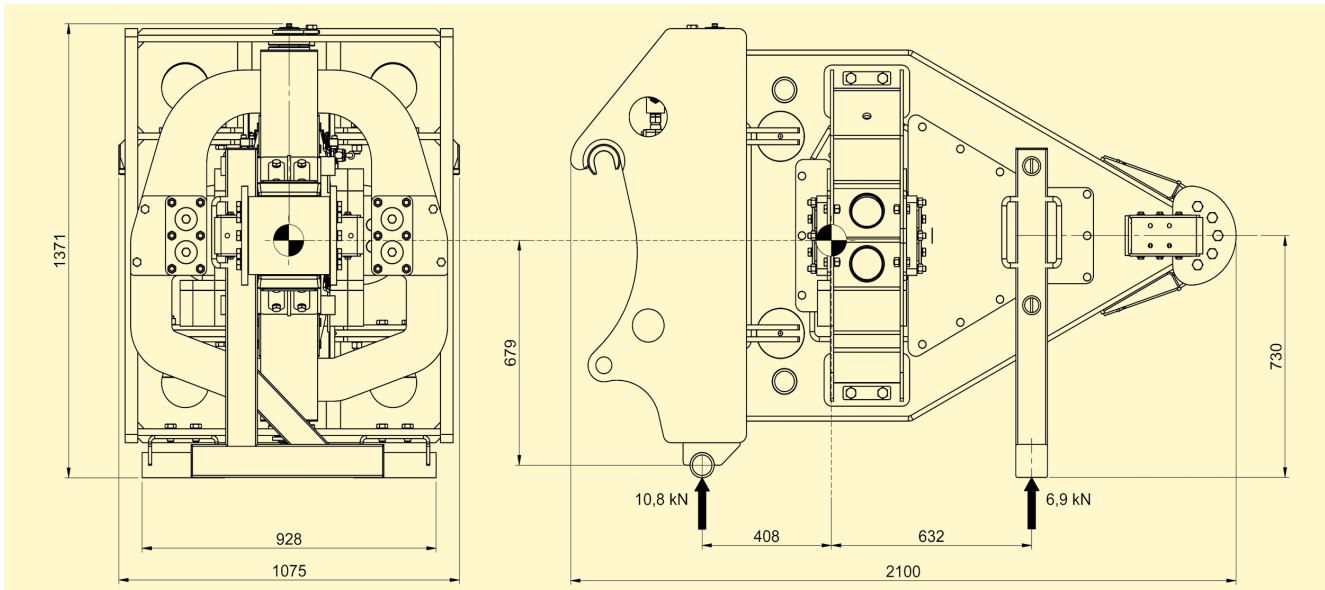

Wheel loader with vibrating unit NHW



Emptying device on the wagon



Cleaning from adhering ashes

Applications

The hydraulically driven wagon emptying device series NHW is used for mobile cleaning of adhesions from wagons.

Design and functioning

The vibrating unit is operated on a carrier (e.g. a wheel loader) with quick-change connector. The integrated drive generates linear vibrations with an impact of up to 108 kN. The transmission of the vibrations to the wagon contact point is effected via a pushrod and an elastic impact unit shoe, which also serves to tilt the trough. This energy input causes the wagon to vibrate, thus cleaning existing adhesions and incrustations from the wagon.

Permissible operating conditions

Drive medium:

Mineral oil according to DIN 51524/25,
Motor oil according to DIN 51511,
Bio oils of the group "HEES"

Operating pressure:

60 to 250 bar

Ambient temperature:

-20 °C to 50 °C

NetterVibration offers the right accessories required for the mounting, installation and control of vibrators and interval impactors.

Netter provides solutions.

Consult our experienced application technicians.

Netter GmbH

Fritz-Lenges-Str. 3
55252 Mainz-Kastel

- Germany
- Switzerland
- Poland
- Spain
- Australien
- United Kigdom

www.**NetterVibration**.com
info@**NetterVibration**.com