



## NetterVibration Accessories

- Electronic and pneumatic controls
- Brackets and fastening sets
- Electric and compressed air installation components
- Control and maintenance units
- Measuring and switching units
- Frequency converters and valves





# NetterVibration



## Accessories for vibrators and vibration systems



Vacuum fixing device with NCT 29 on container



Maintenance unit with ball valve and manifold



Maintenance unit, on/off switch and frequency control at the vibrating table



Frequency measurement with VibroScanner at the vibrating table



Vibration monitoring system at conveyor with blade springs



CC unbalances on 2 NEG's at vibrating table  
Coil springs made of stainless steel

### Applications

NetterVibration accessories will be used on all devices.

The applications range from simple fixing components, control and switching devices to complete control and maintenance units.

A special facet of the accessories is measuring systems for rotational speed, frequency and acceleration measurement, the values of which are used for process control.

The reduction of the noise level and energy savings are always top priorities.

In addition to standard accessories NetterVibration offers a wide range of special solutions, adapted to suit the individual requirements of the client.

NetterVibration has a worldwide staff of experienced application engineers and field representatives. We would be pleased to offer advice on site and to help optimize your applications using vibration technology.

We would be pleased to prove our consulting competence in connection with a free trial of our test units.

**Netter provides solutions.  
Contact our experienced application technicians.**

### Netter GmbH

#### Germany

Fritz-Ullmann-Str. 9  
55252 Mainz-Kastel  
Tel. +49 6134 2901-0

#### Poland

Al. W. Korfantego 195/17  
40-153 Katowice  
Tel. +48 32 2050947

#### Switzerland

Erlenweg 4  
4310 Rheinfelden  
Tel. +41 61 8316200

#### Spain



















Errota Kalea 8  
20150 Villabona-Guipúzcoa  
Tel. +34 943 694 994

www.[NetterVibration.com](http://NetterVibration.com)  
info@[NetterVibration.com](mailto:NetterVibration.com)

04/2015 Subject to change without notice

## Accessories











Unit description	Applications	Leaflet
<b>Control systems</b> <ul style="list-style-type: none"> <li>Electronic timer</li> <li>Pneumatic time control</li> <li>Pneumatic time control</li> <li>Sequence control</li> <li>Control cabinet</li> </ul>	<ul style="list-style-type: none"> <li>AP 116</li> <li>PAP 115</li> <li>PAP 116</li> <li>NAS</li> <li>NSS</li> </ul>	<ul style="list-style-type: none"> <li>Electronic control of vibrators</li> <li>Pneumatic control, exact to the second</li> <li>Pneumatic control, exact to the minute</li> <li>Control of duty, pause and waiting time</li> <li>Pneumatic controls</li> </ul>  
<b>Fastening devices</b> <ul style="list-style-type: none"> <li>Vacuum fixing device</li> <li>Fastening set</li> <li>Quick-release bracket</li> <li>Quick-release clamp</li> <li>Weld-on bracket</li> </ul>	<ul style="list-style-type: none"> <li>VAC</li> <li>NBS</li> <li>NVH</li> <li>SVS</li> <li>ASB</li> </ul>	<ul style="list-style-type: none"> <li>Installation of vibrators without fixed mounting</li> <li>Impactors and electric external vibrators</li> <li>Pneumatic external vibrators</li> <li>Pneumatic and electric vibrators</li> <li>Fastening devices for PKL and NEG</li> </ul>  
<b>Maintenance components</b> <ul style="list-style-type: none"> <li>Supply unit</li> <li>Maintenance unit</li> <li>Lubricator</li> <li>Regulator</li> <li>Fan or heater</li> </ul>	<ul style="list-style-type: none"> <li>NVE</li> <li>NWE</li> <li>NOE</li> <li>NFR</li> </ul>	<ul style="list-style-type: none"> <li>Compressed air supply with controls</li> <li>Especially for Netter pneumatic vibrators</li> <li>Continuous oil atomization</li> <li>Compliance with the required compressed air quality</li> <li>Cooling or heating at extreme temperatures</li> </ul>  
<b>Frequency converter</b> <ul style="list-style-type: none"> <li>Adjustable frequency controls</li> <li>Adjustable frequency controls</li> <li>Adjustable frequency controls</li> <li>Electronic frequency converter</li> <li>Terminal box</li> </ul>	<ul style="list-style-type: none"> <li>SRF</li> <li>ATV</li> <li>NFU</li> <li>NFC</li> <li>NEG – NFU</li> </ul>	<ul style="list-style-type: none"> <li>Continuous speed control</li> <li>Speed control for installation in a switch cabinet</li> <li>Speed control for wall mounting</li> <li>Power supply of the electric vibrators</li> <li>Connection of several vibrators</li> </ul>  
<b>Control elements</b> <ul style="list-style-type: none"> <li>VibroMonitor</li> <li>Timer</li> <li>Braking device</li> <li>Motor protection circuit-breaker</li> <li>Group switching</li> </ul>	<ul style="list-style-type: none"> <li>NVM</li> <li>BZ</li> </ul>	<ul style="list-style-type: none"> <li>Vibration monitoring system</li> <li>Electronic time relay</li> <li>Switching off vibrators without them running on</li> <li>Overload protection for electric vibrators</li> <li>Switching between vibration groups</li> </ul>  
<b>Measuring devices</b> <ul style="list-style-type: none"> <li>Vibration measuring system</li> <li>Hand-held LED stroboscope</li> <li>Sirometer</li> <li>Measuring labels</li> <li>Incremental rotary encoder</li> </ul>	<ul style="list-style-type: none"> <li>VibroScanner</li> </ul>	<ul style="list-style-type: none"> <li>Acceleration and frequency measurement</li> <li>Contactless measurement of speed and frequency</li> <li>Measurement of speed of rotation</li> <li>Measurement of vibration</li> <li>Conversion of rotary motion into electric signals</li> </ul>  
<b>Operating, switching and display elements</b> <ul style="list-style-type: none"> <li>Touch panel</li> <li>Main switch, mushroom button, light barrier</li> <li>Weighing controller</li> <li>Remote control</li> <li>Large-scale display</li> </ul>		<ul style="list-style-type: none"> <li>Operation of the frequency control</li> <li>On-off or emergency-off</li> <li>Analysis of weighing cells</li> <li>Operation from an external place</li> <li>Large-size display of the vibration frequency</li> </ul>   
<b>Valves</b> <ul style="list-style-type: none"> <li>3/2-way solenoid valve</li> <li>3/2-way air valve</li> <li>3/2-way solenoid valve</li> <li>2/2-way and mini ball valve</li> <li>Throttle check valve</li> </ul>	<ul style="list-style-type: none"> <li>HVI</li> <li>LVI</li> <li>MVI, MVH, MVF</li> <li>KH</li> <li>EAS</li> </ul>	<ul style="list-style-type: none"> <li>Connections</li> <li>1/8" and 1/4"</li> <li>1/4", 1/8" and 1/2"</li> <li>1/4" and 1/2"</li> <li>Manual operation</li> <li>1/8" to 2"</li> </ul>  
<b>Bearing elements</b> <ul style="list-style-type: none"> <li>Coil springs made of stainless steel</li> <li>Leaf springs</li> <li>Rubber buffers</li> <li>Pneumatic spring bellows</li> <li>Connecting element</li> </ul>	<ul style="list-style-type: none"> <li>NVD</li> <li>NJ, NK, NL, NN</li> <li>NRE, NTE, NOF, NAP</li> <li>FlexiLink</li> </ul>	<ul style="list-style-type: none"> <li>Elastic bearing and support</li> <li>Design of conveyor systems</li> <li>Damping and isolation of vibrations</li> <li>Maintenance-free bearing and height adjustment</li> <li>Mounting element vibrator – conveyor</li> </ul>  



## Leaflet

## Unit description

## Applications

 	<p><b>Safety accessories</b></p> <ul style="list-style-type: none"> <li>- Silencer made of plastic, sintered metal, ceramics</li> <li>- Protective caps, bellows</li> <li>- Soundproof hood</li> <li>- Elastomer inlay</li> <li>- Safety rope</li> <li>- Power choke and filter, sinus filter</li> </ul> <p style="text-align: right;">EE kit NSE</p>	<ul style="list-style-type: none"> <li>- Use depending on temperature</li> <li>- Accident prevention and dust protection</li> <li>- Reduction of noise level</li> <li>- For silenced impacts</li> <li>- Protection against falling down</li> <li>- Filtering out power faults or interfering signals</li> </ul>
 	<p><b>Accessories for electric external vibrators</b></p> <ul style="list-style-type: none"> <li>- CC unbalances with 2 different settings</li> <li>- Special unbalances according to customer specification</li> <li>- Spacer</li> <li>- PTC resistor</li> <li>- Ball and roller bearing</li> </ul>	<ul style="list-style-type: none"> <li>- Unbalance setting of 25% to 100%</li> <li>- Customized unbalance setting</li> <li>- Compensation of removed unbalances</li> <li>- For safe operation of vibrators</li> <li>- Maintenance of vibrators</li> </ul>
 	<p><b>Installation accessories</b></p> <p>Rubber and plastic hoses for different temperature ranges</p> <ul style="list-style-type: none"> <li>- Hose clamps</li> <li>- Screw connections, nozzles, L-, T- and double nipples</li> <li>- High-temperature hoses for synchronous operation and HT ranges</li> <li>- O-rings and gaskets</li> <li>- Automatic control PKL, ST kit for continuous impact sequence</li> </ul>	
 	<p><b>General accessories</b></p> <ul style="list-style-type: none"> <li>- Fastening screws, lock washers, self-locking screws and nuts,</li> <li>- Locking fluid</li> <li>- Glue for mounting screws, sealant for air supply lines</li> <li>- Pneumatic oil, hydraulic oil, filter inserts, bearing grease, cable lugs</li> <li>- Weights, additional weights to change the working moment</li> </ul>	





35

## Netter Timer Type AP 117 and Series PAP

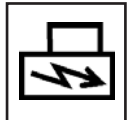

- Adjustment exact to the second
- Dust and water-splash protected
- For the control of electric and pneumatic vibrators



AP 117



PAP 115



PAP 116



## Netter Timer Type AP 117 and Series PAP

Type	AP 117	PAP 115	PAP 116
Operation mode	electric, non-contact	pneumatic	pneumatic
Adjustment	digital	analogue	analogue
Duty time	hh : mm : ss, 1 s to 99 h	3 s to 180 s (down)	3 s to 180 s (down)
Pause time	hh : mm : ss, 1 s to 99 h	3 s to 180 s (up)	3 min to 100 min (up)
Switching current	AC / DC: 1,25 A	-	-
Own consumption	2 VA (in operation), 0,25 VA (standby)	-	-
Input/output*	AC 90 V – 240 V (50/60 Hz) DC 24 V – 48 V ± 5 %	1/8"	1/8"
Operation pressure	-	minimum 3 bar	minimum 3 bar
Ambient temperature	- 20°C to 60°C	- 10°C to 60°C	- 10°C to 60°C
Protection	IP 65, radio interference suppression	IP 66	IP 66
Housing	polycarbonate	Al	Al

\*Input voltage = output voltage

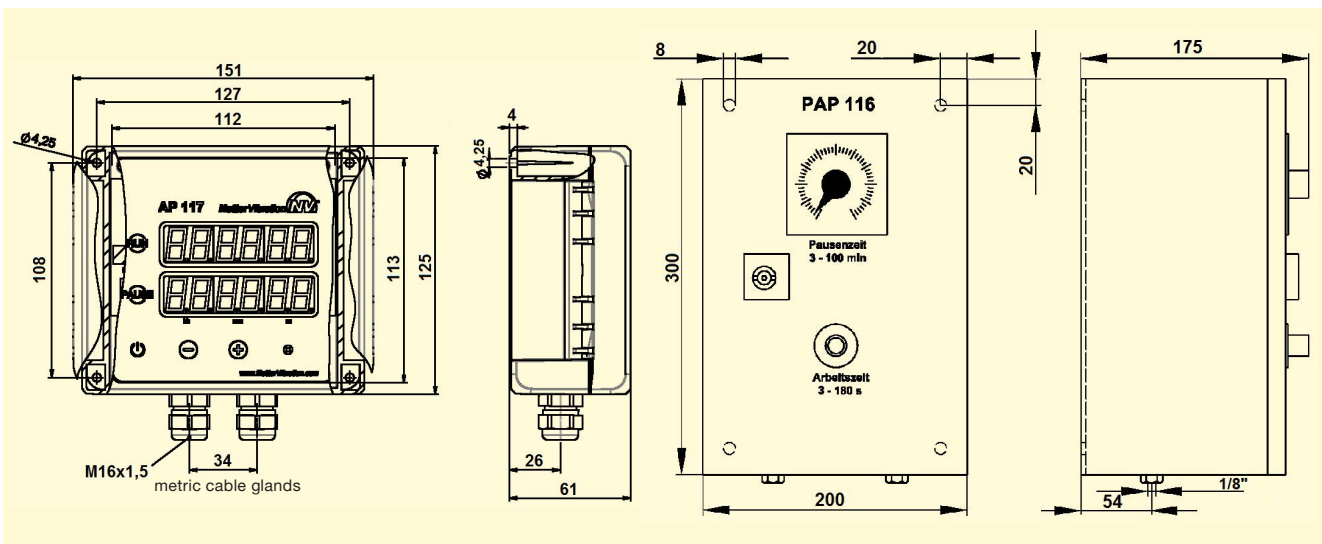

### AP 117

#### Applications

The electronic timer AP 117 is used to control pneumatic and electric vibrators. The advantages of temporary vibrator application are noise level reduction energy saving.

#### Construction and Working Principle

The electronic timer is used to operate solenoid valves or motor overheating protection at freely selectable intervals. The sequence begins with the duty time, which can be adjusted from 1 s to 99 h. During this time the supply voltage is applied to the consuming device being controlled. When the duty time ends, the pause time of 1 s to 99 h runs, then the duty time, etc.

Moreover, the electronic timer AP 117 provides an interval mode in which the duty time is divided into clock duty times (pulses) and clock pulse times with an adjustable length of 1 to 59 s each.

The elapsed time is visible on the display. The AP 117 can be used separately or integrated in a switching cabinet.

### PAP 115 and PAP 116

#### Applications

Series PAP pneumatic time controls are suitable for interval control of vibrators, as well as the control of impactors (PKL). The times can be continuously adjusted.

#### Construction and Working Principle

Activation (on/off) with a directional control valve. The PAP can actuate all directional valves, but is not sufficient for the direct activation of consuming devices. It must be ensured that enough adequately sized actuation valves are provided for vibrators, etc. The pause time of the PAP 115 can be adjusted exact to the second, that of the PAP 116 exact to the minute. Use filtered (filter  $\leq 5 \mu\text{m}$ ) compressed air. Constant pressure guarantees reproducible times.

NetterVibration offers the accessories required for the mounting, installation, control and monitoring of vibrators and impactors.

**Netter provides solutions.**  
**Consult our experienced application technicians.**

#### Netter GmbH

##### Germany

Fritz-Ullmann-Str. 9  
55252 Mainz-Kastel  
Tel. +49 6134 2901-0

##### Poland

Al. W. Korfantego 195/17  
40-153 Katowice  
Tel. +48 32 2050947

##### Switzerland

Erlenweg 4  
4310 Rheinfelden  
Tel. +41 61 8316200

##### Spain

Errota Kalea 8  
20150 Villabona-Guipúzcoa  
Tel. +34 943 694 994

[www.NetterVibration.com](http://www.NetterVibration.com)  
[info@NetterVibration.com](mailto:info@NetterVibration.com)



## Sequence Controls / Control Cabinets Series NAS / NSS

- **Controlling and standardising production processes, ensuring quality**
- Individual duty, pause and idle time settings
- Automatic recognition of connected components
- Maintenance-free
- Dust and splash-water protected



NASmini 8 AC/DC



NASmini 16 AC/DC



NSS



## Sequence Controls / Control Cabinets Series NAS / NSS

Type	NASmini 8	NASmini 16	NSS
Mains voltage	90 V to 260 V AC or 24 V DC	100 V to 240 V AC or 24 V DC	Control cabinets of the series NSS can be manufactured according to customer requirements.
Output voltage	24 V DC $\pm$ 10 % (short-circuit protected)	24 V DC $\pm$ 10 % (short-circuit protected)	
Own consumption	3 W	max. 30 W (24 V DC); 30 VA (100 – 240 V AC)	
Duty time	0,5 s to 30 s	1 s to 99 s	
Pause time	2 s to 540 s	1 s to 999 s	
Idle time	-	0 to 999 min	
Number of sequences	0 to 9	0 to 9	
Number of outputs	1 to 8	1 to 16, with an extension up to 64	
Ambient temperature	-20 °C to 50 °C	-20 °C to 50 °C	
Dimensions BxHxT	180 x 130 x 77 mm	200 x 150 x 80 mm	
Housing / IP code	Makrolon® housing / IP 65	Makrolon® housing / IP 65	

### Dimensions of NASmini 16 und NASmini 8 [mm]

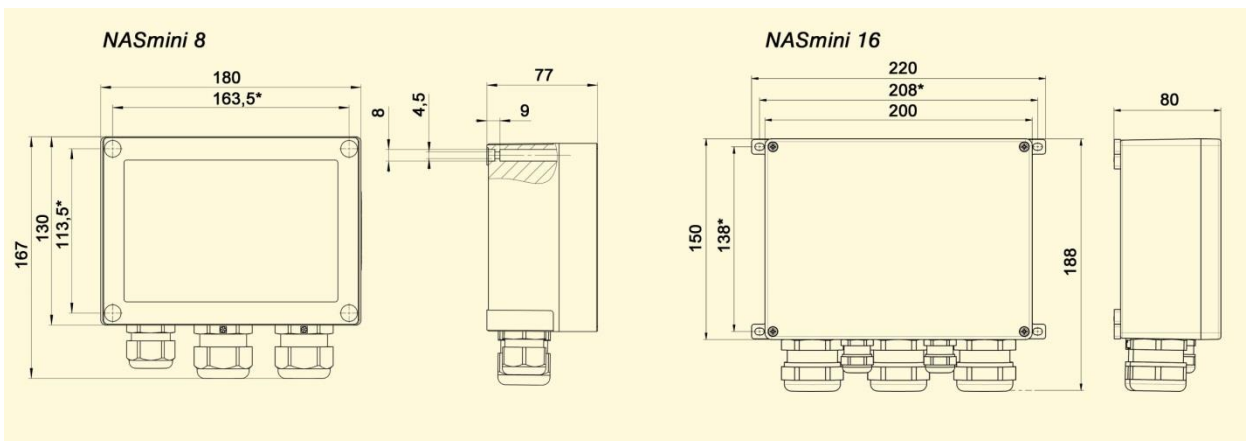

\*mounting dimensions

### Netter Sequence Controls Series NAS

#### Applications:

Wherever processes are standardised and continuously high quality must be guaranteed, the Netter Sequence Control Series NAS is applied. This enables processing of sequential procedures. Appropriately selected intervals for duty and pause times of the vibrators optimise operational processes by saving drive energy and lowering continuous sound level.

#### Design and working principle:

The sequence controls actuate solenoid valves or motor contactors at freely definable intervals. The duty times of the vibrators, the pause times between the duty times and the number of sequences are adjustable. NAS sequence controls can run control tasks in NSS control cabinets.

#### Features:

The NASmini 16 includes the function of the AP 117 and is, with extensions, able to actuate up to 64 devices.

### Netter Control Cabinets Series NSS

#### Application fields:

The control cabinets of the series NSS are used for clocked control of pneumatic and/or electric vibrators.

#### Design and working principle:

Idle, pause and duty times can be chosen freely. A cyclical repetition of duty times and vibration monitoring can be integrated in the controls as required by the customer. We manufacture control cabinets of the series NSS according to your requirements.

NetterVibration offers suitable accessories for assembly, installation, actuation and monitoring of vibrators and impactors.

**Netter provides solutions. Consult our experienced application technicians.**

### Netter GmbH

**Germany**  
Fritz-Ullmann-Str. 9  
55252 Mainz-Kastel  
Tel. +49 6134 2901-0

**Poland**  
Al. W. Korfantego 195/17  
40-153 Katowice  
Tel. +48 32 2050947

**Switzerland**  
Erlenweg 4  
4310 Rheinfelden  
Tel. +41 61 8316200

**Spain**  
Errota Kalea 8  
20150 Villabona-Guipúzcoa  
Tel. +34 943 694 994

www.**NetterVibration**.com  
Info@**NetterVibration**.com





15

## Netter Vacuum Fixing Devices for Vibrators Series VAC



- Quick mounting without bolting or welding
- Strong connection due to high vacuum
- Can also be used on curved or uneven surfaces
- Optional air economizer
- ATEX conform and stainless steel versions available
- Customized versions possible



VAC 10 with NCT 4



VAC 15 with PKL 740 ST



VAC 30 with NTS 50/04



## Netter Vacuum Fixing Devices for Pneumatic Vibrators Series VAC

Type + Hose set	Air consumption without vibration [l/min]		Weight [kg]	Minimum-Ø for round containers [mm]	Suitable vibrators						
	4 bar	6 bar			NCB	NCR	NCT	NTK	NTS	NTP	PKL
VAC 8 +HG 10 N	40	60	0,95	110	1, 2		1, 2	8 AL, 15 X	120 HF, 120NF*	25**	
VAC 8 +HG 10 S	20	22	1,20					16, 18 AL	180HF, 180NF*		
VAC 10+HG 10 N	40	60	1,05	110	1, 2, 3	3	3, 4	15X, 18AL	180HF, 180NF*	25**	190**
VAC 10+HG 10 S	20	22	1,30						250HF, 250NF*		
VAC 11 +HG 10 N	40	60	1,25	110	3, 5	10	5, 10	18 AL	180HF, 180NF		190**
VAC 11 +HG 10 S	20	22	1,50								
VAC 12+HG 15 N	60	122	2,85	350	10, 20	22	15, 29	25 AL	350HF, 350 NF	25**, 32**, 48**	450**
VAC 12+HG 15 S	29	36	3,20								
VAC 13+HG 15 N	110	170	4,20	850	10, 20	22	15, 29		75/01, 50/01 70/02*	32**	740, 2100
VAC 13+HG 15 S	41	52	4,55								
VAC 15+HG 15 N	110	170	3,40	650	10, 20	22	15, 29	18AL, 25	250HF, 250NF, 350HF, 350NF	32, 48*	740
VAC 15+HG 15 S	41	52	3,75								
VAC 20+HG 15 N	110	170	7,25	850		57	55, 108		70/02, 54/02, 50/04*	32, 48	2100
VAC 20+HG 15 S	41	52	7,60								
VAC 30+HG 30 N	110	170	11,50	1.500		120	126, 250		50/04, 50/08*	NVG 49, 55, 61 NVG 82, 84*	5000
VAC 30+HG 30 S	49	60	12,00								
VAC 40+HG 40 N	220	340	20,00	1.500					50/08*, 50/10*		

The technical data are comparative values and can vary depending on the application. Additional data available upon request. Subject to technical changes. \*Depending on application, please consult **NetterVibration**. \*\*Adapter plate necessary, please include in order!

Type	Model	A [mm]	B [mm]	C [mm]	D [mm]	E [mm]	F [mm]	Type	Model	A [mm]	B [mm]	C [mm]	D [mm]	E [mm]	F [mm]
VAC 8	I	19	8	150	127	30	55	VAC 13	III	70	30	186	241	195	197
VAC 10	I	22	8	200	175	26,5	55	VAC 15	II	56	25	345	290	100	150
VAC 11	I	20	5,5	300	276	26	55	VAC 20	II	70	30	425	370	150	200
VAC 12	I	25	10	300	268	68	100	VAC 30	IV	70	30	396	339	426	370
								VAC 40	V	70	25	426	375,6	425	370

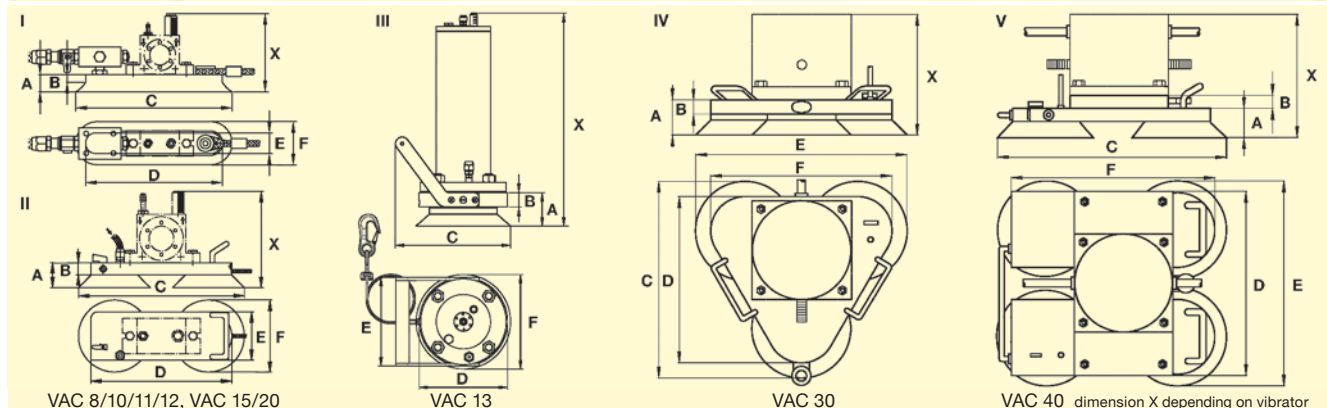

### Application

The vacuum fixing devices VAC are designed to allow quick attachment of vibrators to smooth or, under circumstances, uneven and curved surfaces. A special feature of the vacuum fixing is the ease of attachment, which requires no welding or bolting.

### Construction and working principle

The appropriate vibrator is screwed to the vacuum fixing and connected to the supply hose leading to the hand valve.

As soon as the vacuum fixing is connected to the compressed air supply, the unit is sucked tightly to the mounting surface, thus ensuring a strong connection between the vibrator and the surface.

The air economizer "S" creates a reduced vacuum, which is sufficient to clamp the vibrator when it is not running and which reduces the air consumption by over 30%.

ATEX conform vacuum fixings series VAC and units with stainless steel plate are available. When the vibrator starts, the fixing device automatically produces the full vacuum.

### Permissible operating conditions Drive medium:

Compressed air or nitrogen (Filter ≤ 5 µm)

### Operating pressure:

2 bar to 6 bar

### Ambient temperature:

-10°C to 60°C

**NetterVibration** offers the accessories required for mounting, installation, control and monitoring of vibrators and impactors.

**Netter provides solutions.**

**Consults our experienced application technicians.**

### Netter GmbH

#### Germany

Fritz-Ullmann-Str. 9  
55252 Mainz-Kastel  
Tel. +49 6134 2901-0

#### Poland

Al. W. Korfantego 195/17  
40-153 Katowice  
Tel. +48 32 2050947

#### Switzerland

Erlenweg 4  
4310 Rheinfelden  
Tel. +41 61 8316200

#### Spain

Errota Kalea 8  
20150 Villabona-Guipúzcoa  
Tel. +34 943 694 994

www.**NetterVibration.com**  
info@**NetterVibration.com**



## Weld-on Brackets Series ASB



- Fixing devices for pneumatic impactors and vibrators
- For Mounting at round and square containers
- The impulse will be spread over evenly
- Greatest possible protection of the weld

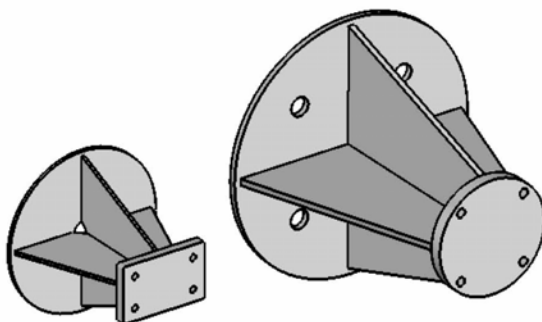

ASB R round

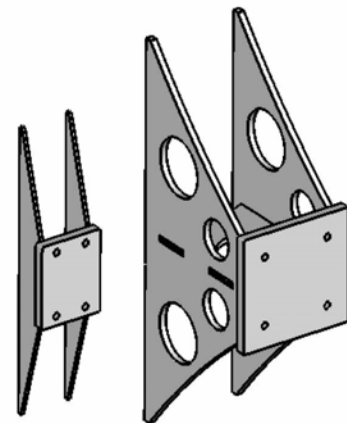

ASB G straight



## Weld-on Brackets Series ASB

### Weld-on Brackets straight Series ASB G

For round and square containers **without insulation**

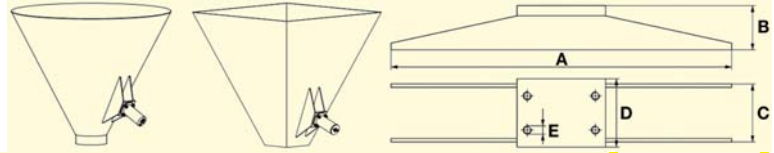

Type	for Impactors	Dimensions [mm]					Material
		A	B	C	D	E	
ASB - G 190	PKL 190	350	46	38	40	M 8	Steel
ASB - G 190 S	PKL 190	350	46	38	40	M 8	Stainless Steel
ASB - G 450	PKL 450	450	60	60	80	M 12	Steel
ASB - G 450 S	PKL 450	450	60	60	80	M 12	Stainless Steel
ASB - G 740	PKL 740	450	65	85	100	M 12	Steel
ASB - G 740 S	PKL 740	450	65	85	100	M 12	Stainless Steel
ASB - G 740 AL	PKL 740	450	65	99	120	Ø 12,5	Aluminium
ASB - G 2100	PKL 2100	600	65	169	180	M 12	Steel
ASB - G 2100 S	PKL 2100	600	65	169	180	M 12	Stainless Steel
ASB - G-5000	PKL 5000	600	70	169	190	M 16	Steel
ASB - G-5000 S	PKL 5000	600	70	169	190	M 16	Stainless Steel

For round and square containers **with heat and sound insulation**

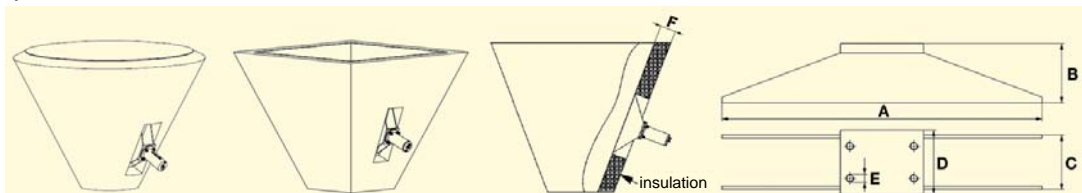

Type	For Impactors	Designation	Dimensions [mm]					Material	
			A	B	C	D	E		F
ASB - G 740	PKL 740	ASB - G 740-200	450	200	85	100	M 12	180	Steel
		ASB - G 740-250		250				230	
		ASB - G 740-300		300				280	
		ASB - G 740-350		350				330	
		ASB - G 740-400		400				380	
ASB - G 740 S	PKL 740	ASB - G 740 S-200	450	200	85	100	M 12	180	Stainless Steel
		ASB - G 740 S-250		250				230	
		ASB - G 740 S-300		300				280	
		ASB - G 740 S-350		350				330	
		ASB - G 740 S-400		400				380	
ASB - G 2100	PKL 2100	ASB - G 2100-200	600	200	160	180	M 12	180	Steel
		ASB - G 2100-250		250				230	
		ASB - G 2100-300		300				280	
		ASB - G 2100-350		350				330	
		ASB - G 2100-400		400				380	
ASB - G 2100 S	PKL 2100	ASB - G 2100 S-200	600	200	160	180	M 12	180	Stainless Steel
		ASB - G 2100 S-250		250				230	
		ASB - G 2100 S-300		300				280	
		ASB - G 2100 S-350		350				330	
		ASB - G 2100 S-400		400				380	
ASB - G-5000	PKL 5000	ASB - G-5000-200	600	200	169	190	M 16	180	Steel
		ASB - G-5000-250		250				230	
		ASB - G-5000-300		300				280	
		ASB - G-5000-350		350				330	
		ASB - G-5000-400		400				380	
ASB - G-5000 S	PKL 5000	ASB - G-5000 S-200	600	200	169	190	M 16	180	Stainless Steel
		ASB - G-5000 S-250		250				230	
		ASB - G-5000 S-300		300				280	
		ASB - G-5000 S-350		350				330	
		ASB - G-5000 S-400		400				380	



## Weld-on Brackets Series ASB



### Weld-on Brackets round Series ASB R

For square containers with heat and sound insulation

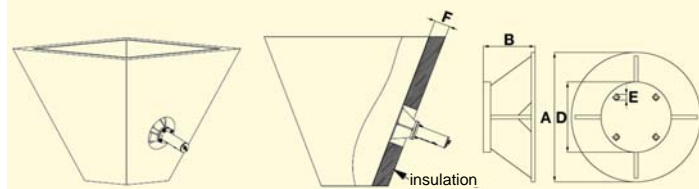

Type	For Impactors	Designation	Dimensions [mm]					Material
			A	B	D	E	F	
ASB – R 740	PKL 740	ASB – R 740-200	250	200	160	M 12	180	Steel
		ASB – R 740-250	250	250			230	
		ASB – R 740-300	350	300			280	
		ASB – R 740-350	350	350			330	
		ASB – R 740-400	350	400			380	
		ASB – R 740-450	450	450			430	
		ASB – R 740-500	450	500			480	
ASB – R 740 S	PKL 740	ASB – R 740 S-200	250	200	160	M 12	180	Stainless Steel
		ASB – R 740 S-250	250	250			230	
		ASB – R 740 S-300	350	300			280	
		ASB – R 740 S-350	350	350			330	
		ASB – R 740 S-400	350	400			380	
		ASB – R 740 S-450	450	450			430	
		ASB – R 740 S-500	450	500			480	
ASB – R 2100	PKL 2100	ASB – R 2100-200	300	200	180	M 12	180	Steel
		ASB – R 2100-250	300	250			230	
		ASB – R 2100-300	400	300			280	
		ASB – R 2100-350	400	350			330	
		ASB – R 2100-400	400	400			380	
		ASB – R 2100-450	500	450			430	
		ASB – R 2100-500	500	500			480	
ASB – R 2100 S	PKL 2100	ASB – R 2100 S-200	300	200	180	M 12	180	Stainless Steel
		ASB – R 2100 S-250	300	250			230	
		ASB – R 2100 S-300	400	300			280	
		ASB – R 2100 S-350	400	350			330	
		ASB – R 2100 S-400	400	400			380	
		ASB – R 2100 S-450	500	450			430	
		ASB – R 2100 S-500	500	500			480	
ASB – R 5000	PKL 5000	ASB – R 5000-200	350	200	180	M 16	180	Steel
		ASB – R 5000-250	350	250			230	
		ASB – R 5000-300	400	300			280	
		ASB – R 5000-350	400	350			330	
		ASB – R 5000-400	450	400			380	
		ASB – R 5000-450	450	450			430	
		ASB – R 5000-500	500	500			480	
ASB – R 5000 S	PKL 5000	ASB – R 5000 S-200	350	200	180	M 16	180	Stainless Steel
		ASB – R 5000 S-250	350	250			230	
		ASB – R 5000 S-300	400	300			280	
		ASB – R 5000 S-350	400	350			330	
		ASB – R 5000 S-400	450	400			380	
		ASB – R 5000 S-450	450	450			430	
		ASB – R 5000 S-500	500	500			480	



**NetterVibration**



**Weld-on Brackets  
Series ASB**

**Weld-on Brackets**

**Series ASB G**

For Vibrators

Type	for Vibrators	Dimensions [mm]					Material
		A	B	C	D	E	
ASB - G	PKL 190	220	40	50	—	M 8	steel
	NCT 3, NCT 4						
	NTS 180, NTS 250, NTS 350						
ASB - G S	PKL 190	220	40	50	—	M 8	stainless steel
	NCB 1, NCB2, NCB 3, NCB 5						
	NCT 3, NCT 4						
ASB - G NCB	NCR 3	400	60	80	—	—	stainless steel
	NTS 180, NTS 250, NTS 350						
ASB - G NTP 25 S	NCB 3, NCB 4	220	48	50	60	M 6	stainless steel
ASB - G NTP 32	NTP 25	450	65	75	85	M 10	steel
		220	150	—	□75	M 10	
ASB - G NTP 32 S	NTP 32	450	65	75	85	M 10	stainless steel
		220	150	—	□75	M 10	
ASB - G NTP 48	NTP 48	600	65	86	100	M 12	steel
ASB - G NTP 48 S	NTP 48	600	65	86	100	M 12	stainless steel
ASB - G NTS	NTS 50/01, NTS 75/01	450	60	100	110	M 8	steel
ASB - G NTS	NTS 50/04	300	200	160	180	M 12	steel
	NTS 54/02	550	60	116	125	M 8	
ASB - G NTS S	NTS 50/01, NTS 75/01	450	60	100	110	M 8	stainless steel
	NTS 50/04	450	65	106	150	M 12	

**Applications:**

The Weld-on Brackets series ASB are secure fastening devices for Netter pneumatic impactors series PKL.

Due to the special design of the Weld-on Brackets, the impulse of the PKL will be spread over evenly across the container wall for loosening the bulk materials, with the greatest possible protection of the weld.

Weld-on brackets are welded directly to the container walls.

PKL impactors will be screwed on plane stiffening profiles, weld-on brackets or weld-on plates (± 0,1 mm planeness).

Welding plates are welded on stiffening profiles or previously mounted on intermediate layers (1.5 times the plate thickness of the container).

The assembly of the impactors is then made with NBS kits on these devices.

**NetterVibration** offers the accessories required for the mounting, installation, control and monitoring of vibrators and impactors.

**Netter provides solutions. Consult our experienced application technicians.**

**Netter GmbH**

**Germany**

Fritz-Ullmann-Str. 9  
55252 Mainz-Kastel  
Tel. +49 6134 2901-0

**Poland**

Al. W. Korfatego 195/17  
40-153 Katowice  
Tel. +48 32 2050947

**Switzerland**

Erlenweg 4  
4310 Rheinfelden  
Tel. +41 61 8316200

**Spain**

Errota Kalea 8  
20150 Villabona-Guipúzcoa  
Tel. +34 943 694 994

www.**NetterVibration.com**  
info@**NetterVibration.com**

04/2015 Subject to change without notice



## Netter Fastening Sets for Electric External Vibrators Series NBS

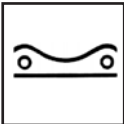

- Safe and solid attachment of the Electric External Vibrators
- Versions for threaded or clearance bores



NBS G



NBS D

## Netter Fastening Sets for Electric External Vibrators Series NBS

Vibrator Type	NBS Type	Fastening plates T [mm]
NEA 504	NBS G 5/20	10
	NBS D 5/30	8
NEA 5020 NEA 5050	NBS G 6/20	10
	NBS D 6/30	8
NEA 5060	NBS G 8/30	15
	NBS D 8/45	10
NEA 50120 NEA 50200 NEA 50300	NBS G 12/45	20
	NBS D 12/60	12
NEA 50550	NBS G 16/55	25
	NBS D 16/80	15
NEA 50770	NBS G 16/70	25
	NBS D 16/90	15
NED 50100	NBS G 8/30	15
	NBS D 8/45	10
NED 50500	NBS G 12/40	25
	NBS D 12/50	15
NED 601110	NBS G 16/65	40
	NBS D 16/100	

Vibrator Type	NBS Type	Fastening plates T [mm]
NEG 5060	NBS G 8/30	15
	NBS D 8/45	10
NEG 5020      NEG 5050	NBS G 6/20	10
	NBS D 6/30	8
NEG 1630    NEG 25210 NEG 1690    NEG 50120 NEG 2530    NEG 50200 NEG 2570    NEG 50300	NBS G 12/45	20
	NBS D 12/60	12
NEG 12460    NEG 251800 NEG 12640    NEG 252060 NEG 16810    NEG 502020 NEG 161130    NEG 502270 NEG 161420    NEG 501540 NEG 251410    NEG 501800	NBS G 16/50	25
	NBS D 16/70	15
NEG 12100    NEG 25540 NEG 16190    NEG 50550 NEG 25420	NBS G 16/55	25
	NBS D 16/80	15
NEG 12230    NEG 16500 NEG 12930    NEG 50980 NEG 16410    NEG 501140	NBS G 16/60	25
	NBS D 16/80	15
NEG 16310    NEG 50770 NEG 12180    NEG 25700	NBS G 16/70	25
	NBS D 16/90	15
NEG 121430    NEG 252370 NEG 12900    NEG 253050 NEG 161610    NEG 253720 NEG 162110    NEG 254310 NEG 162550    NEG 503400 NEG 163030    NEG 503820	NBS G 20/60	30
	NBS D 20/80	20
NEG 122150    NEG 164700 NEG 122640    NEG 254900 NEG 163820	NBS G 24/55	35
	NBS D 24/90	25
NEG 122920    NEG 168500 NEG 123530    NEG 256460 NEG 124440    NEG 258040 NEG 165190    NEG 506220 NEG 166270    NEG 508830 NEG 167890	NBS G 24/70	35
	NBS D 24/95	25
NEG 127640    NEG 258260 NEG 166670	NBS G 36/85	50
	NBS D 36/120	35
NEG 128520    NEG 2511210 NEG 1217670    NEG 2513850 NEG 1612060	NBS G 42/100	60
	NBS D 42/130	40
NEG 1211070    NEG 1613890 NEG 1213160    NEG 1617000	NBS G 42/105	60
	NBS D 42/140	40

NBS G

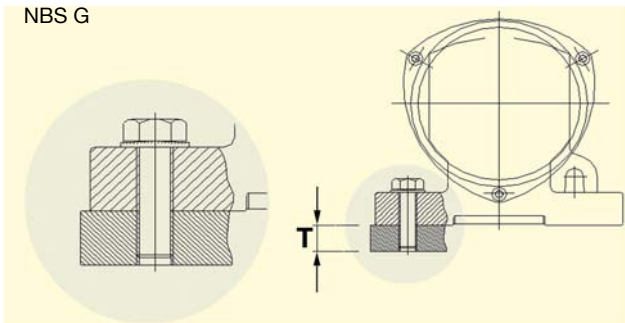

NBS D

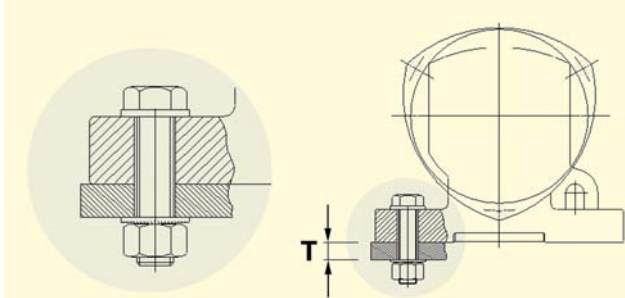

### Applications:

The NBS fixing sets provide a safe and solid attachment of the NEA, NED bzw. NEG vibrators.

**NetterVibration** provides on request, these NBS fixing sets (screws, springs, matching washers).

**NetterVibration** offers the accessories required for the mounting, installation, control and monitoring of vibrators and impactors.

**Netter provides solutions.**  
Consult our experienced application technicians.

### Netter GmbH

#### Germany

Fritz-Ullmann-Str. 9  
55252 Mainz-Kastel  
Tel. +49 6134 2901-0

#### Poland

Al. W. Korfańtego 195/17  
40-153 Katowice  
Tel. +48 32 2050947

#### Switzerland

Erlenweg 4  
4310 Rheinfelden  
Tel. +41 61 8316200

#### Spain

Errota Kalea 8  
20150 Villabona-Guipúzcoa  
Tel. +34 943 694 994

www.**NetterVibration.com**  
info@**NetterVibration.com**





## Netter Fastening Sets for Pneumatic Linear Vibrators Series NBS

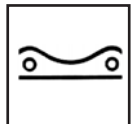

- Safe and solid attachment of the Linear Vibrators
- Versions for threaded or clearance bores



NBS G



NBS D



## Netter Fastening Sets for Pneumatic Linear Vibrators Series NBS

Vibrator Type	NBS Type	Fastening plate T [mm]
NTS 75/01 NTS 50/01 NTS 70/02 NTS 54/02	NBS G 8/30 NBS D 8/45	15
NTS 21/04	NBS G 12/35	15
	NBS D 12/55	20
NTS 50/10 NTS 30/10	NBS G 16/35 NBS D 16/55	20
	NBS G 16/45 NBS D 16/65	20
NTS 50/15 NTS 50/20 NTS 30/20 NTS 24/20	NBS G 20/50 NBS D 20/70	20
NTS 50/40 NTS 20/40	NBS G 24/65 NBS D 24/80	20

Vibrator Type	NBS Type	Fastening plate T [mm]
NTP 25	NBS G 6/25 NBS D 6/40	15
NTP 32	NBS G 10/30 NBS D 10/50	15
NTP 25	NBS G 12/35	15
	NBS D 12/50	20
NTP 48	NBS G 12/40 NBS D 12/60	15

NBS G

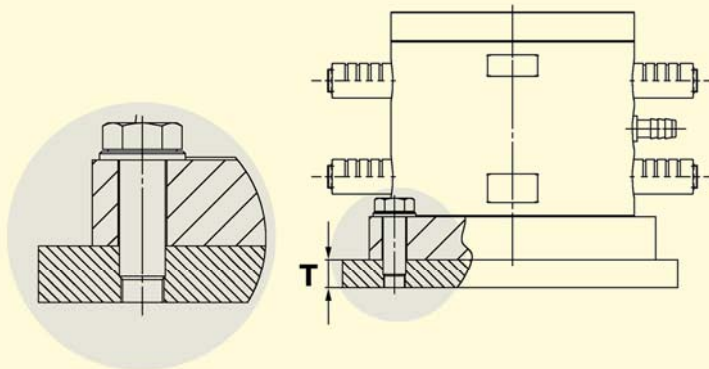

NBS D

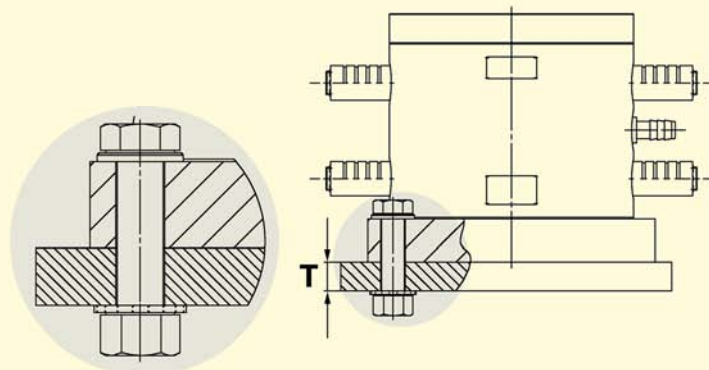

### Applications:

The NBS fixing sets provide a safe and solid attachment of the NTS and NTP Vibrators.

**NetterVibration** provides on request, these NBS fixing sets (screws, springs, matching washers).

**NetterVibration** offers the accessories required for the mounting, installation, control and monitoring of vibrators and impactors.

**Netter provides solutions. Consult our experienced application technicians.**

### Netter GmbH

#### Germany

Fritz-Ullmann-Str. 9  
55252 Mainz-Kastel  
Tel. +49 6134 2901-0

#### Poland

Al. W. Korfanteo 195/17  
40-153 Katowice  
Tel. +48 32 2050947

#### Switzerland

Erlenweg 4  
4310 Rheinfelden  
Tel. +41 61 8316200

#### Spain

Errota Kalea 8  
20150 Villabona-Guipúzcoa  
Tel. +34 943 694 994

www.**NetterVibration**.com  
info@**NetterVibration**.com



## Netter Fastening Sets for PKL Series NBS

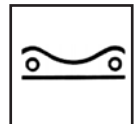

- Safe and solid attachment of the PKL impactors
- Versions for threaded or clearance bores



NBS 740 for PKL 740



NBS 2100 for PKL 2100  
or NBS 5000 for PKL 5000



## Netter Fastening Set for PKL Series NBS

Impactor Type	NBS Type	Fastening screws	Fastening plates thickness [mm]
PKL 740	NBS 740		
PKL 740	NBS G 740	M12x60	15
PKL 740	NBS D 740	M12x90	15
PKL 2100	NBS 2100		
PKL 2100	NBS G 2100	M12x50	15
PKL 2100	NBS D 2100	M12x90	15
PKL 5000	NBS 5000		
PKL 5000	NBS G 5000	M16x75	20
PKL 5000	NBS D 5000	M16x110	20

### Mounting procedure using the example of the NBS 740 D on a PKL 740

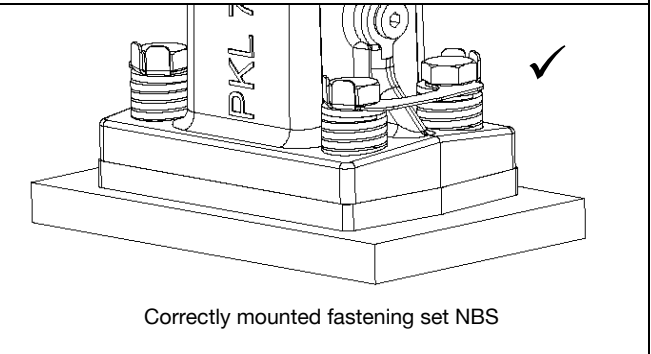
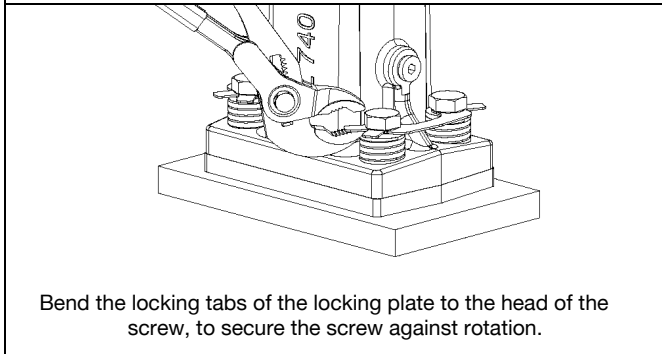
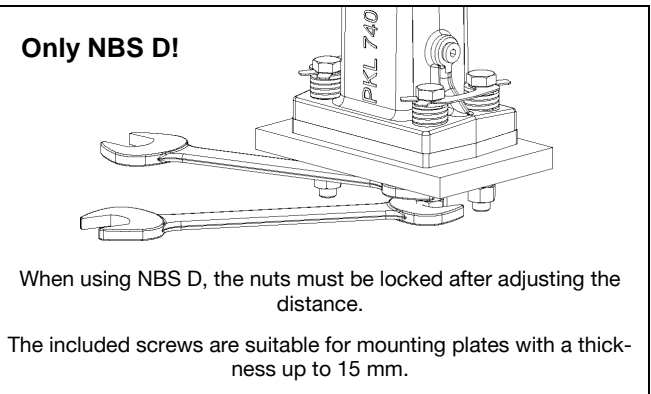
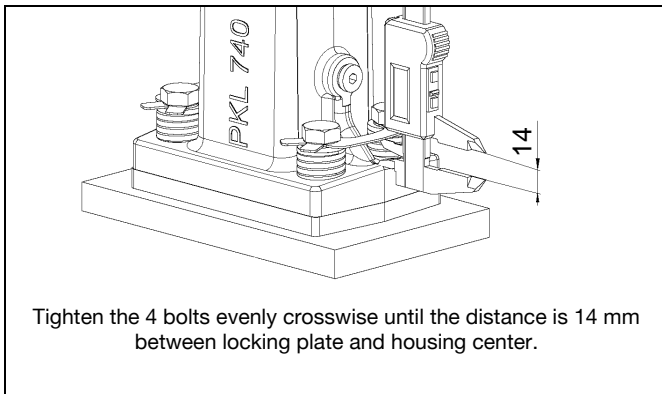

#### Applications:

The NBS fixing sets provide a safe and solid attachment of the PKL impactors.

**NetterVibration** provides on request, these NBS fixing sets (screws, springs, matching washers).

**NetterVibration** offers the accessories required for the mounting, installation, control and monitoring of vibrators and impactors.

**Netter provides solutions.**  
Consult our experienced application technicians.

#### Netter GmbH

##### Germany

Fritz-Ullmann-Str. 9  
55252 Mainz-Kastel  
Tel. +49 6134 2901-0

##### Poland

Al. W. Korfantego 195/17  
40-153 Katowice  
Tel. +48 32 2050947

##### Switzerland

Erlenweg 4  
4310 Rheinfelden  
Tel. +41 61 8316200

##### Spain

Errota Kalea 8  
20150 Villabona-Guipúzcoa  
Tel. +34 943 694 994

www.**NetterVibration.com**  
info@**NetterVibration.com**





## Netter Quick-Clamping Devices Series SVS



- Fast attachment to different containers
- Economic use of vibrators
- Low weight, easy handling
- Suitable for pneumatic or electric vibrators



SVS 4 S



SVS 4 D



## Netter Quick-Clamping Devices Series SVS

Type	Version	Usable vibrators
SVS 4 S (T)	With toggle screw	Pneumatic vibrators: NCT, NCB, NCR, NVG, NTK, NTS and NTP
SVS 4 D (T)	With pressure can	Electric vibratos up to approx. 3000 N at 3000/min. up to approx. 1500 N at 1500/min.

T version with carrier plate. Versions made of stainless steel can be supplied.

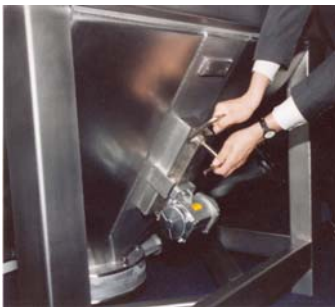
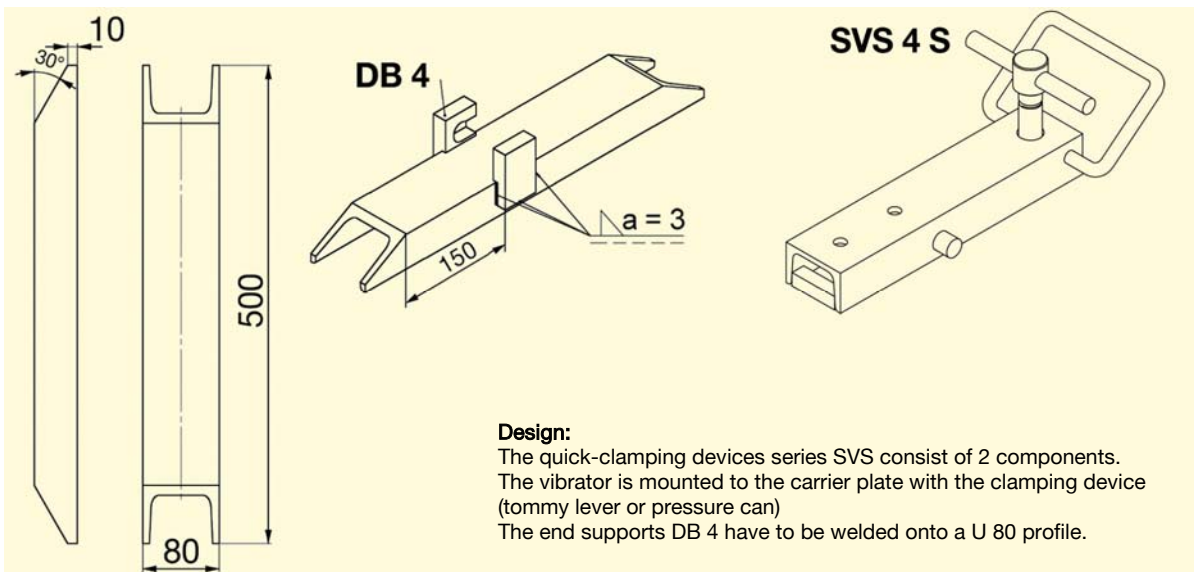

SVS 4 ST with NEA

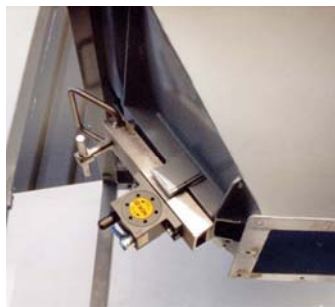

SVS 4 S with NCR



SVS 4 D with NTS

### Applications:

Due to its low weight the quick-clamping device can be easily inserted into the end supports. For reinforcement we recommend to weld the U-profile with a fine welding seam onto the entire length of the trough. The quick-clamping device SVS 4 S is inserted into the carrier plates's end supports up to the stop and fastened with the toggle screw.

A force-locking connection between device and end supports is obtained. Now the vibrator can be started.

In version SVS-4 D the clamping occurs automatically when the compressed air supply is switched on.

**NetterVibration** offers the required accessories for mounting, installation, control and monitoring of the vibrators and impactors.

**Netter provides solutions.**  
Contact our experienced application technicians.

### Netter GmbH

**Germany**  
Fritz-Ullmann-Str. 9  
55252 Mainz-Kastel  
Tel. +49 6134 2901-0

**Poland**  
Al. W. Korfantego 195/17  
40-153 Katowice  
Tel. +48 32 2050947

**Switzerland**  
Erlenweg 4  
4310 Rheinfelden  
Tel. +41 61 8316200

**Spain**  
Errota Kalea 8  
20150 Villabona-Guipúzcoa  
Tel. +34 943 694 994

www.**NetterVibration**.com  
info@**NetterVibration**.com



## Pneumatic Maintenance Units Series NWE

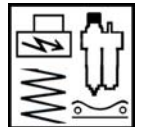

- For use in the ATEX zones 1, 2, 21 and 22
- Preparation of compressed air especially for pneumatic vibrators
- Ensures compressed air of consistently high quality
- With grade of filtration 5 µm as standard for pure compressed air
- Continuous oil atomization



Lubricator NOE ¼, NOE ½



Filter regulator NFR ¼, NFR ½



Maintenance unit NWE 1



## Pneumatic Maintenance Units Series NWE

### Maintenance units

Type	Ordering number	Nominal width/ connection P	Pressure range [bar]	Inlet pressure max. [bar]	Flow rate [l/min]	Weight [kg]	Filter [µm]	Dimensions in mm													
								A	B	C	D	E	F	G	H	I	J	K	L	M	N
NWE 1/4	81881114	G¼	0.5 - 10	10	1,750	1.20	5	226	137	114	96	108	99	92	5.4	128	116	110	50	49	24
NWE 1/2	81881112	G½	0.5 - 10	10	3,500	2.00	5	257	163	144	110	120	108	100	6.4	155	141	132	35	49	41
NWE 1	81881110	G1	0.5 - 10	10	10,500	4.55	5	382	214	157	128	83	-	-	8.4	124	98	66	20	61	19

### Filter regulators

Type	Ordering number	Nominal width/ connection P	Pressure range [bar]	Inlet pressure max. [bar]	Flow rate [l/min]	Weight [kg]	Filter [µm]	A	B	C	D	E	F	G	H	I	J	K	L	M	N
NFR 1/4	81885114	G¼	0.5 - 10	10	1,750	0.90	5	226	85	109	96	108	99	92	5.4	76	64	58	50	49	24
NFR 1/2	81885112	G½	0.5 - 10	10	3,500	1.47	5	257	101	139	110	120	108	100	6.4	92	77	69	36	49	41
NFR 1	81886110	G1	0.5 - 10	10	11,000	2.53	5	382	124	164	128	83	-	-	8.4	-	98	66	20	61	19

### Lubricators

Type	Ordering number	Nominal width/ connection P	Pressure range [bar]	Inlet pressure max. [bar]	Flow rate [l/min]	Weight [kg]	Filter [µm]	A	B	C	D	E	F	G	H	I	J	K	L	M	N
NOE 1/4	81882114	G¼	0.5 - 10	10	1,750	0.72	-	186	85	76	64	108	99	92	5.4	76	64	58	80	-	24
NOE 1/2	81882112	G½	0.5 - 10	10	3,500	1.20	-	210	100	106	70	120	108	100	6.9	92	77	69	90	-	41
NOE 1	81882110	G1	0.5 - 10	10	18,000	2.03	-	358	124	122	85	83	-	-	8.4	-	98	66	30	-	19

All maintenance units with manual drain, pressure gauge, mounting plate or bracket and filter

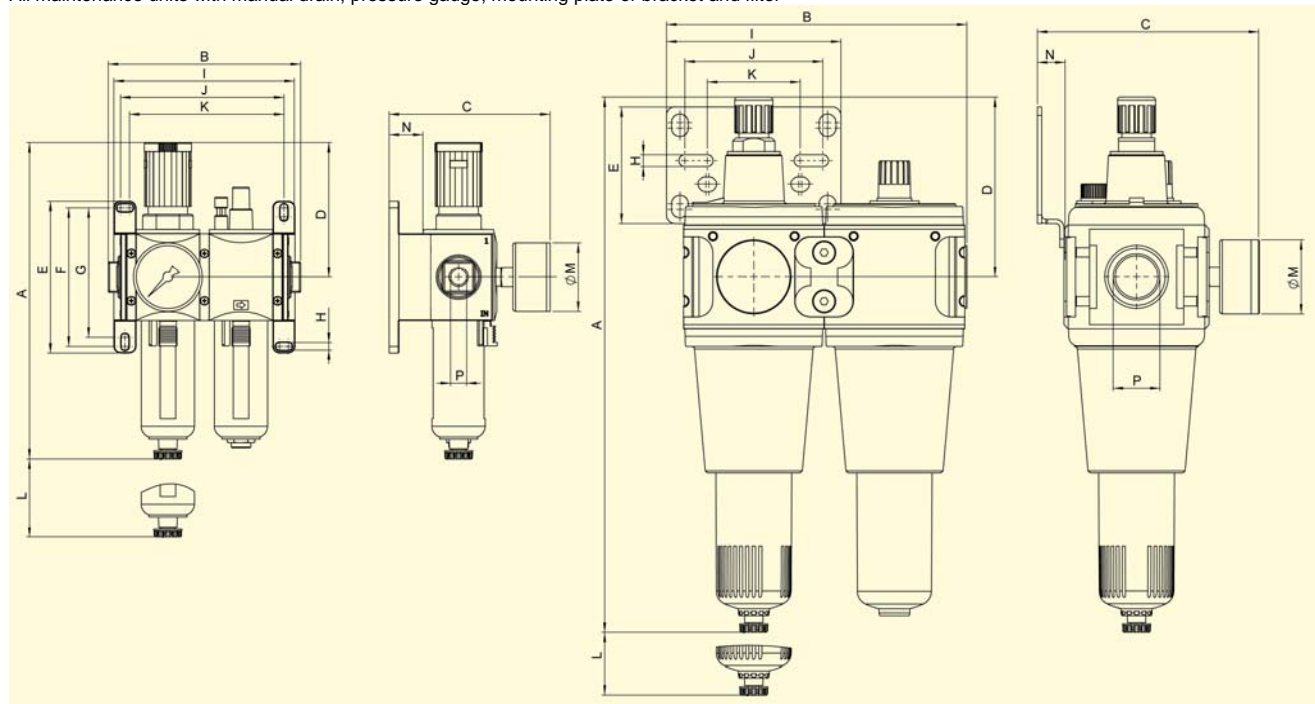

NWE ¼ and NWE ½

NWE 1

### Applications:

The maintenance units and their individual components supply pneumatic vibrators with pure lubricated compressed air. They improve the reliability and service life of pneumatic equipment.

NWE, NFR and NOE are especially suitable for pneumatic piston vibrators. The pressure variations caused by piston vibrators have no influence on the function of the components (regulator, lubricator).

The maintenance units guarantee the trouble-free operation of all air-operated vibrators by continuously atomizing the oil.

The maintenance units are suitable for the use in hazardous areas of zone 1, 2, 21 and 22.

### Design and functioning principle:

The pneumatic maintenance units consist of the filter regulator (filter, manometer, manual drain, mounting plate) and the lubricator.

The 5 µm filter inside the filter regulator (condensate reservoir) cleans the compressed air. At the same time the required pressure can be adjusted.

The lubricator atomizes the pneumatic oil. The compressed air leaves the maintenance unit clean and sufficiently lubricated (oil quantity adjustable).

The table shows the technical data of maintenance units and their individual components which work reliably in continuous and intermittent operation.

### Admissible operating conditions

#### Drive media:

Compressed air or nitrogen

#### Operating pressure:

0,5 bar to 10 bar

#### Ambient temperature:

0°C to 50°C

NetterVibration offers the accessories required for mounting, installation, control and monitoring of vibrators and impactors.

### Netter provides solutions.

Consult our experienced application technicians.

### Netter GmbH

#### Germany

Fritz-Ullmann-Str. 9  
55252 Mainz-Kastel  
Phone +49 6134 2901-0

#### Poland

Al. W. Korfantego 195/17  
40-153 Katowice  
Phone +48 32 2050947

#### Switzerland

Erlenweg 4  
4310 Rheinfelden  
Phone +41 61 8316200

#### Spain

Errota Kalea 8  
20150 Villabona-Guipúzcoa  
Phone +34 943 694 994

www.NetterVibration.com  
info@NetterVibration.com



36

## Netter Static Adjustable Frequency Controls Series SRF / NFU / ATV

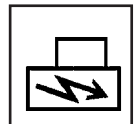

- Infinitely adjustable speed control of electric external and internal vibrators
- Parallel connection of multiple vibrators
- Simple and robust design
- Clearly arranged menu navigation
- Special versions according to customer







# NetterVibration



## Netter Static Adjustable Frequency Controls Series SRF



Type	Supply Voltage	Max. Motor-		Dimensions (W x H x D) [mm]
		Power Input [kW]	Current [A]	
SRF 1-007/4,8	1 ~ 200..240V 50/60Hz	0,75	4,8	300 x 400 x 200
SRF 1-011/6,9		1,10	6,9	
SRF 1-022/11		2,20	11,0	
SRF 2-007/2,3	3 ~ 380..415V 50/60Hz	0,75	2,3	400 x 500 x 250
SRF 2-015/4,1		1,50	4,1	
SRF 2-022/5,5		2,20	5,5	
SRF 2-040/9,5		4,00	9,5	
SRF 2-055/14,3		5,50	14,3	
SRF 2-075/17		7,50	17,0	600 x 600 x 300
SRF 2-110/27,7		11,00	27,7	
SRF 2-150/33		15,00	33,0	



### Switch Cabinet

As a standard, the frequency control systems of the series SRF are mounted in switch cabinets. These switch cabinets are suitable for wall mounting and provide protection against dust and splash water (Protection type IP54). Netter SRF are also available as switch cabinet with socket, with frame and as desk version.

The standard color is light grey. (RAL 7035), other colors or a stainless steel enclosure are available. The motor outputs are connected to a terminal strip or, if requested by the customer, the housing of the switch cabinet is provided with plug connections.

The dimensions of the switch cabinet depend on the size of the frequency converter.

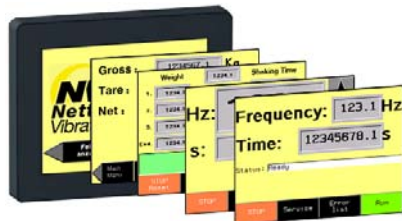

### Operation

As a standard, the SRF can be operated and controlled using a 3.5" color touch panel. The vibration process can be started and stopped by this panel. By buttons or a keyboard the operator can enter the desired frequency and shaking time, readable on large displays. As languages G/E/F can be selected.

The CC unbalance function (big/small working moment) and a control group for two vibrating tables are stored in the program and can be activated if required. Error messages and alarms are displayed in separate windows which simplifies maintenance and service. Depending on the customer's requests, the size of the touch panel and the program of the SRF can be adjusted to suit the requirements on site.

### Configuration

If requested, **NetterVibration** can configure additional inputs and outputs on the SRF, therewith safety devices or external operating units can be connected

to the SRF. An optional mini control system allows complex monitoring and control tasks.

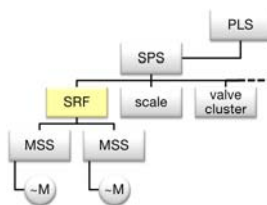

### Bus Communication

Netter SRF can be used for all kinds of communication configurations in industrial plants.

The communication via Modbus, CANopen and other bus systems is possible after consultation with **NetterVibration**.

When the SRF is integrated into an existing production process, it communicates with the central process control system.



### Avoiding Uncontrolled Resonances

The integrated braking function in the frequency converter helps to prevent uncontrolled oscillation when decelerating the vibrators. This might have a negative effect on the vibration result.

Depending on the application and for the control of multipole vibrators with high working moments we recommend the use of separate brake resistors.

## Netter Static Adjustable Frequency Converter Series NFU



Type	Supply Voltage	Max. Motor-		Dimensions (W x H x D) [mm]
		Power Input [kW]	Current [A]	
NFU 1-004/3,3	1~ 200..240V 50/60Hz	0,4	3,3	210 x 240 x 163
NFU 1-007/4,8		0,75	4,8	
NFU 1-011/6,9		1,1	6,9	215 x 297 x 192
NFU 1-015/8		1,5	8,0	
NFU 1-022/11		2,2	11,0	230 x 340 x 208
NFU 2-004/1,5	3~ 380..415V 50/60Hz	0,4	1,5	215 x 297 x 192
NFU 2-007/2,3		0,75	2,3	
NFU 2-011/3		1,1	3,0	
NFU 2-015/4,1		1,5	4,1	
NFU 2-022/5,5		2,2	5,5	230 x 340 x 208
NFU 2-040/9,5		4,0	9,5	

Netter frequency converters series NFU with motor output in the IP 54 housing for wall-mounting are equipped with an on-off switch, direction switch and potentiometer for frequency setting.

A display at the device shows the output frequency of the converter. The NFU can also communicate with other devices via Modbus or CANopen. The NFU offers the possibility to connect one vibrator. In case two or more vibrators are required, it is necessary to connect an external motor terminal box as well as a motor protection relay.

Optionally, a brake resistor can be mounted and connected to prevent uncontrolled vibrations in critical applications if required. The NFU is pre-adjusted and ready for installation.

### Design

Depending on the application a reserve should be calculated when designing the frequency converter, as bigger vibrators have a higher starting current.

If multi-pole vibrators (4 or 6-pole) are required, we recommend using Netter frequency converters with three-phase supply.

## Netter Static Adjustable Frequency Converter Series ATV



Type	Supply Voltage	Max. Motor-		Dimensions (W x H x D) [mm]
		Power Input [kW]	Current [A]	
ATV-320U07M2C	1~ 200..240V 50/60Hz	0,75	4,8	72 x 143 x 138
ATV-320U11M2C		1,10	6,9	105 x 142 x 158
ATV-320U22M2C		2,20	11,0	105 x 142 x 158
ATV-320U07N4C	3~ 380..415V 50/60Hz	0,75	2,3	105 x 143 x 158
ATV-320U15N4C		1,50	4,1	
ATV-320U22N4C		2,20	5,5	140 x 184 x 158
ATV-320U40N4C		4,00	9,5	
ATV-320U55N4B		5,50	14,3	150 x 232 x 232
ATV-320U75N4B		7,50	17,0	
ATV-320D11N4B		11,00	27,7	
ATV-320D15N4B	15,00	33,0	180 x 330 x 232	

ATV frequency converters are mounted in an IP 2x housing for installation in a customer's existing switch cabinet. The performance data correspond to those of the series SRF.

NetterVibration provides application-specific parameter settings on request.



# NetterVibration

## Netter Static Adjustable Frequency Controls Special version of the series SRF

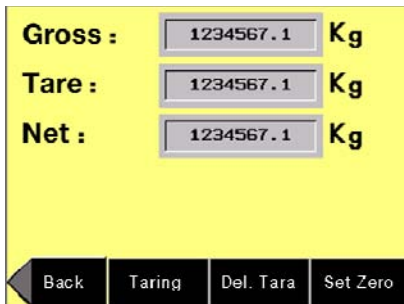

### Integrated Weighing Mechanism

If required, **NetterVibration** offers the SRF with integrated weighing mechanism. It is possible to simultaneously compact and weigh bulk material by mounting weighing cells at the vibration table. The current weight is shown on the touch panel of the SRF. Also weight-dependent shaking applications are possible.

### Pre-adjusted and ready for Installation

All required parameters, such as starting and stopping time, run-up ramp, maximum motor and pulse frequency, slip compensation and U/K characteristic will be pre-adjusted and tested depending on the application by **NetterVibration** before delivery.

After installation and connection at the customers' site the SRF is ready for operation.



### Explosion-proof Control Systems

In dialogue with the user **NetterVibration** implements control systems which fulfil all requirements of the ATEX directive. These control systems comply with the Equipment Group II. Depending on the version it can be used in hazardous areas of the zones 1, 2, 21 or 22.



SRF with vibrating table



Integrated weighing system



SRF and vibrating table made of stainless steel



Vibrating table with roller track

### Applications

The frequency control of the series SRF and the frequency converters of the series ATV and NFU are used for speed regulation of electric vibrators. Special applications require frequencies which cannot be achieved with normal vibrators at line frequency. These frequency converters are characterized by their simple and robust design.

### Design and Functioning Principle

Low-loss power electronics allows the operation at input voltages with high tolerances. The frequency converters generate three-phase voltages with variable frequencies of 0 Hz to 500 Hz, what makes it possible to easily adjust the speed. The permissible temperature range is 0 °C to +40 °C.

All required parameters such as starting and stopping time, run-up ramp, maximum motor and pulse frequency, slip compensation and U/F characteristic are defined by **NetterVibration**.

Optionally a brake resistor can be used for time-critical applications. The brake resistor permits a fast braking within a few revolutions in order to avoid unwanted resonance vibrations.

**NetterVibration** offers the accessories required for the mounting, installation, control and monitoring of vibrators and impactors.

**Netter provides solutions. Consult our experienced application technicians.**

### Netter GmbH

**Germany**  
Fritz-Ullmann-Str. 9  
55252 Mainz-Kastel  
Tel. +49 6134 2901-0

**Poland**  
Al. W. Korfantego 195/17  
40-153 Katowice  
Tel. +48 32 2050947

**Switzerland**  
Erlenweg 4  
4310 Rheinfelden  
Tel. +41 61 8316200

**Spain**  
Errota Kalea 8  
20150 Villabona-Guipúzcoa  
Tel. +34 943 694 994

[www.NetterVibration.com](http://www.NetterVibration.com)  
[info@NetterVibration.com](mailto:info@NetterVibration.com)

02/2017 Subject to change without notice

## Accessories for SRF



### Unit description

#### Switch cabinets as desk version or made of stainless steel

Depending on the customer specification we can also supply the SRF control system in other switch boxes and cabinets including versions made of stainless steel or plastic, versions as floor-standing cabinet or simply on a mounting plate.



#### External operating elements

For external operation of the frequency controls e.g. from a remote panel or direct operating elements at the unit.



#### Braking resistor

To prevent uncontrolled vibration amplitudes when the vibrator stops after being switched off. Ready-mounted in the switch cabinet.



#### Touch panel

The standard 3.5" color TFT touch screen panel will be replaced by a larger 5.7" color TFT touch screen panel. The Netter static adjustable frequency controls of the series SRF can be operated via the touch panel.



#### Group switching

To switch between 2 or several vibration groups at a vibrating table or between 2 or several vibrating tables. Depending on the size of the frequency converter it is possible to operate only a single group or all groups together.



#### Motor protection circuit breaker in the motor feeder

For protection of the electric vibrators against thermal overload and failure of a single or two outer conductors.



#### Safety functions

Depending on the application it may become necessary to assess safety functions such as emergency-off mushroom buttons, protection doors or light barriers in order to be able to brake and stop the vibrators in dangerous situations.



#### Remote control

To start and stop vibration, to reduce or increase the shaking time and to switch the vibration groups.



#### Power choke and filter

Power chokes and filters protect against system overvoltage and reduce the current harmonics generated by the converter. They filter out power faults caused by other consumers and compensate voltage asymmetries between the phases. In addition, they save money (up to 20%), as they limit the mains current without reducing performance.





## Leaflet

## Unit description



### Sinus filter

Sinus filters reduce electric interfering signals on the motor line which can interfere with other consumers. They must always be used for unshielded motor lines.



### Integrated weighing controller

Weighing cells integrated in the system will be analyzed by means of weighing controllers in the SRF control system. The current weight value is shown on the touch panel.



### Fan / heater

For cooling or heating of the built-in switch cabinet elements at extreme environmental temperatures.



### Large-sized displays

For large-scale display of the current vibration frequency e.g. in a production hall.





## Netter On / Off Switches



- Direct or decentralized switching on and off the system
- Main switch lockable
- Large operator pushbuttons



On / off switch



On / off switch with motor protection circuit-breaker



Main switch



## Netter On / Off Switch Series

Type	Main switch	On / off switch	On / off switch with motor protection circuit-breaker	On / off switch with protection circuit-breaker
<b>Housing material</b>	Polycarbonate	Polycarbonate	Polycarbonate	Sheet steel
<b>Protection class</b>	IP 65	IP 65	IP 65	IP 55
<b>Operating temperature</b>	-20°C to 50°C	-5°C to 40°C	-5°C to 40°C	-5°C to 40°C
<b>Voltage range</b>		3 x 400 V~ 1 x 230 V~	1 x 400 V~	1 x 400 V~
<b>Nominal current</b>		9 to 35 A		
<b>Thermal nominal current</b>	16 to 63 A		Adjustable 0.16 to 23 A	Adjustable 0.16 to 10 A
<b>Operation</b>	Emergency off main switch lockable	Start pushbutton green Stop pushbutton red	Emergency off main switch, lockable Start pushbutton white Stop pushbutton black	Emergency off main switch, lockable Start pushbutton green Stop pushbutton red
<b>Pre-punched holes</b>	At the top: 2 M20/25	On the top: 2 M20/25	At the top: 2 PG 13,5 and 2 PG 16	
<b>Cable glands:</b>	At the bottom: 2 M20/25	At the bottom: 2 M20/25 2 motor outputs at the bottom of the housing	At the bottom: 2 PG 13,5 and 2 PG 16	At the bottom: 3 M20 x 1,5
<b>Connectable:</b>	Up to 2 NEG or NEA	Up to 2 NEG or NEA	1 NEG	Up to 2 NEG

### Dimensions [mm]

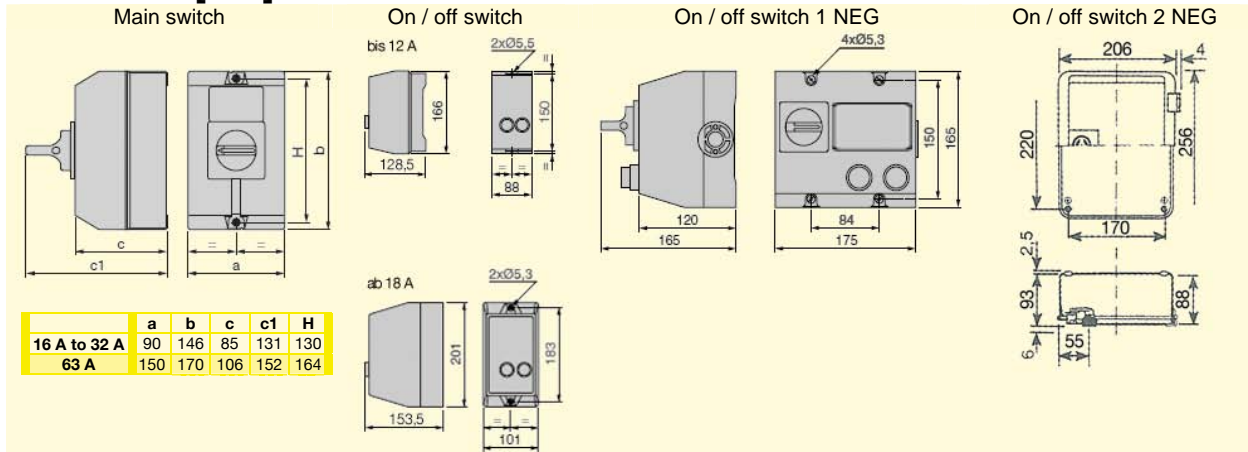

#### Permissible operating conditions

**Ambient temperature:**  
-5°C to 50°C

NetterVibration offers the required accessories for mounting, installation, control and monitoring of vibrators and impactors.

**Netter provides solutions.**  
Contact our experienced application technicians.

#### Netter GmbH

##### Germany

Fritz-Ullmann-Str. 9  
55252 Mainz-Kastel  
Tel. +49 6134 2901-0

##### Poland

Al. W. Korfantego 195/17  
40-153 Katowice  
Tel. +48 32 2050947

##### Switzerland

Erlenweg 4  
4310 Rheinfelden  
Tel. +41 61 8316200

##### Spain

Errota Kalea 8  
20150 Villabona-Guipúzcoa  
Tel. +34 943 694 994

www.**NetterVibration.com**  
info@**NetterVibration.com**



## Netter Vibration Monitoring System Series *VibroMonitor*



- Monitoring the operation of vibrators and impactors
- Constant checkup of vibration systems
- Control unit mounted on M36-DIN rail



NVM C1W

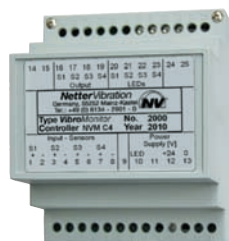

NVM C4



NVM S10



## Netter Vibration Monitoring System Series *VibroMonitor*

<i>VibroMonitor</i>	NVM C1W Control unit	NVM C4W Control unit	NVM C4 Control unit	NVM S10 Sensor
<b>Sensor inputs</b>	1 ■ unpolarised	4 ■ unpolarised	4 ■ unpolarised	 Cylindrical sensor made of stainless steel with 4-pin socket for round connectors M12 × 1 with cap nut and interlock.  <b>Shock acceleration</b> max. 981 m/s <sup>2</sup>  <b>Cable length</b> between sensor and control unit: max. 250 m  Ø 12 × 40, thread (plug) M12 ■ 1 × 1
<b>Relay outputs</b>	1 × potential free change-over	4 × potential free change-over	–	
<b>Digital outputs</b>	1 ■ sensor status, NPN, max. 1 A		4 ■ sensor status, NPN, max. 8 mA	
<b>Setting</b>	–	2 ■ SET inputs	–	
<b>Status-LEDs</b>	1 ■ operating voltage control		1 operating voltage control,	
	1 ■ sensor status	8 ■ sensor status	4 ■ sensor status	
<b>Fault</b>	1 ■ Fault output (cable break or short circuit)		4 ■ visual indicators	
<b>Dimensions H × W × D</b>	70 × 35 × 90 mm	70 × 70 × 90 mm	70 × 70 × 90 mm	
<b>Mounting</b>	M36-DIN-standard rail (EN50022)			

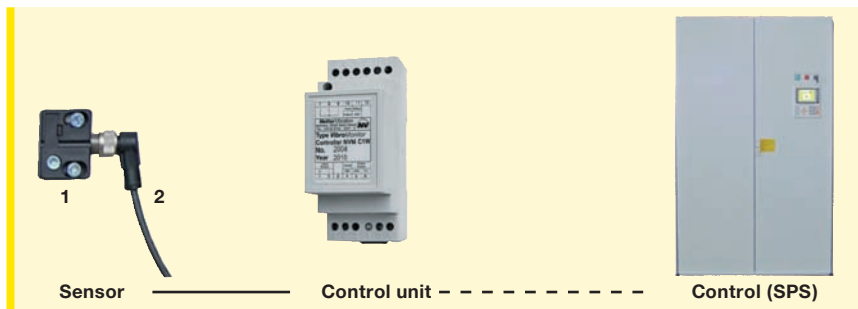

### Accessories

- 1 Sensor clamp support in plastic or rubberised stainless steel pipe clamp.
- 2 Elbow connector M12 × 1 or sensor connector cable with cast elbow connector M12 × 1

### Vibrator monitoring

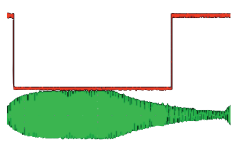

The *VibroMonitor* output (red) shows the acceleration (green) exceeding the switching threshold\* of 9,81 m/s<sup>2</sup>.  
\*Can be adjusted in the factory.

### Impactor monitoring

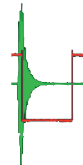

The *VibroMonitor* output (red) holds its status for at least 450 ms. and therefore reliably records even short impacts (green). This signal length is treatable by standard commercial SPCs.

### Applications

The vibration monitoring system series *Vibro-Monitor* is used for the constant monitoring of impactors, vibrators and vibrating systems.

The *VibroMonitor* system reliably monitors the operation of vibrators and impactors, even in locations with difficult access.

### Design and function

The vibration monitoring system consists of sensor, connector cable and control unit. The control unit ensures the safe transmission of the sensor signal up to a maximum cable length of 250 m. Depending on the version up to 4 sensors can be supplied by a control unit.

The system displays two operating status informations per sensor: "Vibration" or "No vibration".

### Permissible operating conditions

#### Operating voltage:

24 V DC (+20% / -10%), < 5% residual ripple

#### Ambient temperature:

C1W and C4W: 0°C to 40°C  
C4 and S10: -20°C to 40 °C

*NetterVibration* offers the accessories required for the mounting, installation, control and monitoring of vibrators and impactors.

### Netter provides solutions.

Consult our experienced application technicians.

### Netter GmbH

#### Germany

Fritz-Ullmann-Str. 9  
55252 Mainz-Kastel  
Tel. +49 6134 2901-0

#### Poland

Al. W. Korfantego 195/17  
40-153 Katowice  
Tel. +48 32 2050947

#### Switzerland

Erlenweg 4  
4310 Rheinfelden  
Tel. +41 61 8316200

#### Spain

Errota Kalea 8  
20150 Villabona-Guipúzcoa  
Tel. +34 943 694 994

www.[NetterVibration.com](http://NetterVibration.com)  
info@[NetterVibration.com](mailto:NetterVibration.com)



## Netter Braking Device Series BZ



- Immediate standstill of electric external vibrators
- Powerfull braking moment
- Compact dimensions



BZ 30



BZ 70





BZ 200





## Netter Braking Devices Series BZ

Braking devices	BZ30	BZ 70	BZ 200
			
<b>Max. braking current</b>	30 A	60 A	200 A
<b>Dimensions HxWxD</b>	68 x 55 x 110 mm	185 x 158 x 110 mm	270 x 145 x 180 mm
<b>Weight</b>	0.5 kg	1.1 kg	7.5 kg
<b>External prefuse</b>	16 A slow-blow	Approx. 150 % of the motor nominal current	
<b>Mounting</b>	M36 DIN standard rail (EN50022)	For mounting in a switch cabinet	
<b>Mains voltage (AC)</b>	3~ 380 V bis 430 V		
<b>Braking voltage (DC)</b>	160 V		
<b>Mains frequency</b>	50 Hz to 60 Hz		
<b>Ambient temperature</b>	0°C to 40°C during operation		
<b>Braking time</b>	0 s to 12 s		

### Applications:

Braking devices serve to brake one or two Netter electric external vibrators.

### Design and functioning principle:

Netter braking devices generate a powerful braking torque. The braking effect is initiated by an adjustable direct current flowing through the motor winding.

A standing magnetic field prevents the motor shaft from moving.

**NetterVibration** offers the accessories required for mounting, installation, control and monitoring of vibrators and impactors.

**Netter provides solutions.**  
**Consult our experienced application technicians.**

### Netter GmbH

#### Germany

Fritz-Ullmann-Str. 9  
55252 Mainz-Kastel  
Tel. +49 6134 2901-0

#### Poland

Al. W. Korfanteo 195/17  
40-153 Katowice  
Tel. +48 32 2050947

#### Switzerland

Erlenweg 4  
4310 Rheinfelden  
Tel. +41 61 8316200

#### Spain

Errota Kalea 8  
20150 Villabona-Guipúzcoa  
Tel. +34 943 694 994

www.**NetterVibration.com**  
info@**NetterVibration.com**



# Netter Vibration Measuring System Series *VibroScanner*



- Acceleration measurements
- Frequency measurements
- Process control



Probe tips



Sensor



Scanner



## Netter Vibration Measuring System Series *VibroScanner*

### VibroScanner



<b>Metering</b>	Root mean square (RMS)	
<b>Ranges</b>	<b>Acceleration measurement</b>	-15 ... 15 g <sub>e</sub> (-147 ... 147 m/s <sup>2</sup> )
	<b>Frequency measurement</b>	5 ... 800 Hz / +/- 0,1 Hz
	<b>Amplitude measurement</b>	+/- 0,1 mm (at sinus)
<b>Resolution</b>	+/- 0,1 g <sub>e</sub> (+/- 1 m/s <sup>2</sup> )	
<b>Measuring accuracy</b>	+/- 3 %	
<b>Damping</b>	-2 dB at 800 Hz	

### Standard equipment:

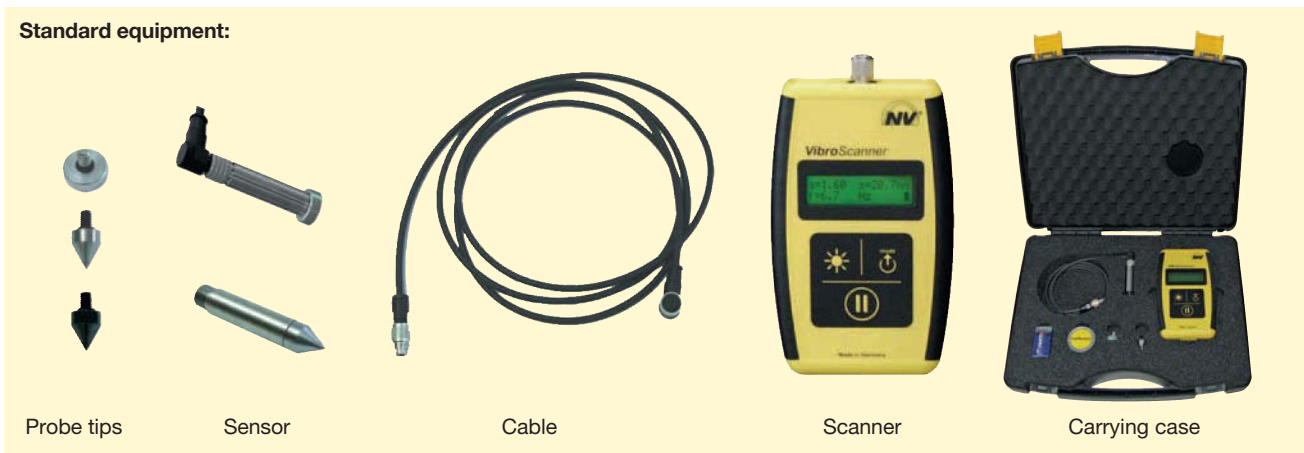

Probe tips

Sensor

Cable

Scanner

Carrying case

### Applications

The *VibroScanner* is used to measure the acceleration and the dominant frequency of mechanical vibrations by means of an acceleration sensor.

Possible applications are the measurement of the operational parameters of vibration systems, e.g. frequencies and effective accelerations in vibration feeders and conveyors, vibration compactors or vibration test systems. Thereby, the *VibroScanner* permits a quantitative process control on a regular basis, thus contributing essentially to the long successful operation of the vibration system. Moreover, it makes it possible for plant manufacturers to perform batch controls in vibration drives in order to ensure a consistent product quality.

### Design and function

The sensor used is a capacitive micro-mechanical (MEMS) sensor characterized by high mechanical strength. The signal processing takes place directly in the sensor housing, thus reducing considerably the sensitivity to electrical interference.

### Admissible operating conditions

#### Operating voltage:

9 V battery

#### Ambient temperature:

-20°C to 40°C

*NetterVibration* offers the accessories required for the mounting, installation, control and monitoring of vibrators and impactors.

### Netter provides solutions.

Consult our experienced application technicians.

### Netter GmbH

#### Germany

Fritz-Ullmann-Str. 9  
55252 Mainz-Kastel  
Tel. +49 6134 2901-0

#### Poland

Al. W. Korfatego 195/17  
40-153 Katowice  
Tel. +48 32 2050947

#### Switzerland

Erlenweg 4  
4310 Rheinfelden  
Tel. +41 61 8316200

#### Spain

Errota Kalea 8  
20150 Villabona-Guipúzcoa  
Tel. +34 943 694 994

www.*NetterVibration*.com  
info@*NetterVibration*.com



## Netter Hand-Held LED Stroboscope



- Speed and frequency measurement with up to 300.000 flashes per minute
- Control of resonance and vibration performance of vibrating systems
- Visualization of vibrations



# NetterVibration



## Netter Hand-Held LED Stroboscope

Flash frequency	30 to 300.000 FPM (flashes per minute)
Accuracy	0.02 % ( $\pm 1$ digit)
Flash power	1500 Lux at 6000 FPM / 20 cm
Dimensions	191 × 82 × 60 mm
Temperature	0°C to 45°C

All adjustments can be made by actuating the pushbuttons with your thumb (one-handed operation).

The multi-line display shows the measured results and the respective units.

Effortless measuring or checking of rotating and vibrating objects.

Generation of still images for quality tests or monitoring of fast-clocked processes.

Vibration of components at different rotational speeds can be made visible.

General contactless speed or frequency measurement of moving objects.

Testing and controlling of resonance and vibration characteristics.

For installation, monitoring and diagnosis in running systems.

**NetterVibration** offers the accessories required for mounting, installation, control and monitoring of vibrators and impactors.

**Netter provides solutions. Consult our experienced application technicians.**

### Netter GmbH

#### Germany

Fritz-Ullmann-Str. 9  
55252 Mainz-Kastel  
Tel. +49 6134 2901-0

#### Poland

Al. W. Korfantego 195/17  
40-153 Katowice  
Tel. +48 32 2050947

#### Switzerland

Erlenweg 4  
4310 Rheinfelden  
Tel. +41 61 8316200

#### Spain

Errota Kalea 8  
20150 Villabona-Guipúzcoa  
Tel. +34 943 694 994

www.**NetterVibration.com**  
info@**NetterVibration.com**





## Directional valves Series HVI, LVI and MVI



- For manual operation of pneumatic vibrators and interval impactors
- Easily exchangeable system
- Compact design



HVI



MVI



LVI



## Directional valves Series HVI, LVI und MVI

Type	Solenoid valves MVI 1/4", MVI 1/2"	Air valves LVI 1/8", LVI 1/4", LVI 1/2"	Manual valves HVI 1/8", 1/4"
Connection	1/4", 1/2"	1/8", 1/4", 1/2"	1/8", 1/4"
Operating pressure	1/4" – 2.5 to 10 bar, 1/2" – 1.5 to 10 bar	0 to 10 bar	2.5 to 10 bar
Flow rate	1/4" - 1.400 NI/min, 1/2" -2,000	1/8" - 850	1/8" – 900, 1/4"- 1,200
Switching frequency	800 min <sup>-1</sup>	-	-
Material	Housing: Aluminium die casting Seals: Rubber NBR	Lacquered zinc die casting Rubber NBR	Zinc die casting Rubber NBR
Voltage	24 V – 230 V AC, 50/60 Hz or 24 V DC		Hand lever,
Power consumption	AC: Switching power: 7.5 VA Holding power 3.5 VA DC: 2.5 W		incremental switch or contact switch
Weight			

Duty time: 100%  
 Protection: IP 65  
 Maintenance: The valves are maintenance-free  
 Mounting: By means of bores in the housing

### Applications:

Mechanically or electronically actuated directional valves serve to actuate pneumatic vibrators and impactors.

Solenoid valves permit the controlled, timed activation of the connected pneumatic vibrators and impactors by electric control signals.

### Permissible operating conditions

#### Drive medium:

Filtered compressed air or nitrogen with or without pneumatic oil

#### Operating pressure:

2.5 bar to 10 bar

#### Ambient temperature:

-15°C to 50°C

*NetterVibration* offers the accessories required for mounting, installation, control and monitoring of vibrators and impactors.

**Netter provides solutions.**

**Consult our experienced application technicians.**

### Netter GmbH

#### Germany

Fritz-Ullmann-Str. 9  
55252 Mainz-Kastel  
Tel. +49 6134 2901-0

#### Poland

Al. W. Korfantego 195/17  
40-153 Katowice  
Tel. +48 32 2050947

#### Switzerland

Erlenweg 4  
4310 Rheinfelden  
Tel. +41 61 8316200

#### Spain

Errota Kalea 8  
20150 Villabona-Guipúzcoa  
Tel. +34 943 694 994

www.[NetterVibration.com](http://NetterVibration.com)  
info@[NetterVibration.com](mailto:NetterVibration.com)



## Coil Springs made of stainless steel

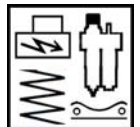

- Elastic support of conveyors and vibrating tables
- Long service life due to additional glass pearl blasting
- Always in stock





## Coil Springs made of stainless steel

Type	Load per coil spring			Outer Ø (D <sub>e</sub> ) [mm]	unloaded(L <sub>0</sub> ) [mm]	Guide Ø (D <sub>d</sub> ) [mm]
	stroke 7,5 mm	[kg]	max			
NVD 2,1/3,1	2,0	to	3,0	27	58	22,3
NVD 3,8/5	3,7	to	5,0	33	50	26,6
NVD 5,2/7,2	3,1	to	6,8	43,2	82	35,8
NVD 7/9,5	3,4	to	9,4	49	103	39,8
NVD 11/16	9,5	to	15,5	36	61	27,1
NVD 13/18	6,6	to	16,7	50	95	38,7
NVD 16/22	14,9	to	21,3	36	53,5	27,1
NVD 18/24	6,9	to	23,5	60	128	47,5
NVD 23/32	11,9	to	30,2	45	95,5	34,0
NVD 30/40	14,6	to	49,7	75	102	59,0
NVD 38/51	24,1	to	51,4	56,3	80	42,6
NVD 39/53	20,1	to	52,6	81	98	63,2
NVD 53/70	12,9	to	70,5	71	205	53,6
NVD 60/80	31,3	to	79,3	71	95	53,6
NVD 85/115	37,3	to	114,5	90	115	68,0
NVD 110/150	50,7	to	150,0	63	111	43,0
NVD 130/180	48,6	to	175,1	73	135	51,0
NVD 145/195	76,4	to	195,7	73	96	51,0

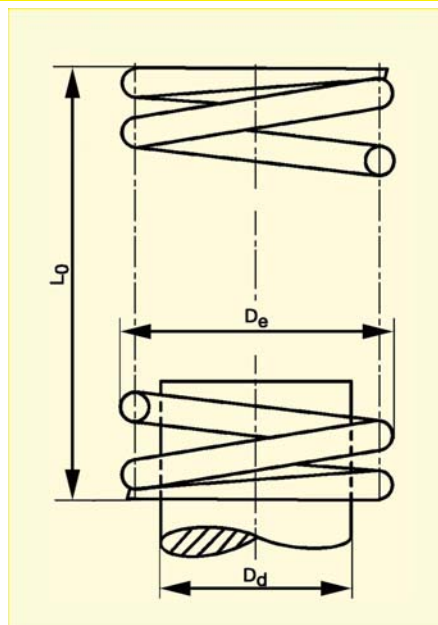

Feeders and discharge troughs need a flexible support, for example coil springs. All springs mounted beneath a feeder tray must be loaded equally to allow constant conveying. It is absolutely necessary to take into consideration the exact position of the centre of gravity of the conveyor tray.

Resonance frequency of the system feeder - springs should be approximately 1/5 of the operating frequency of the vibrator so that the natural frequency of the springs (uncontrolled deflection) is quickly passed through. The max. load per spring can be found in the table. The stroke of the coil spring should be 7,5 mm or more. Twin supports by several pairs of coil springs are also possible.

In the table you will find coil springs that are suitable for the flexible support of conveyors and are always in stock.

For selection of the suitable coil spring you have to divide the weight of the moving mass by the number of springs in order to know the load per coil spring. You can then choose the corresponding coil spring in the table. The coil springs are made of stainless steel wire and the surface is specially treated so that a longer service life can be provided.

**NetterVibration** offers the accessories required for the mounting, installation, control and monitoring of vibrators and impactors.

**Netter provides solutions. Consult our experienced application technicians.**

### Netter GmbH

#### Germany

Fritz-Ullmann-Str. 9  
55252 Mainz-Kastel  
Tel. +49 6134 2901-0

#### Poland

Al. W. Korfantego 195/17  
40-153 Katowice  
Tel. +48 32 2050947

#### Switzerland

Erlenweg 4  
4310 Rheinfelden  
Tel. +41 61 8316200

#### Spain

Errota Kalea 8  
20150 Villabona-Guipúzcoa  
Tel. +34 943 694 994

www.**NetterVibration**.com  
info@**NetterVibration**.com



## Pneumatic Spring Bellows

40, 80, 100, 200 and 330

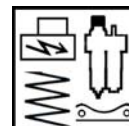

- Elastic support of vibration systems
- Low friction
- Maintenance-free even under rough environmental conditions



40-1



80-3B



## Pneumatic Spring Bellows 40, 80, 100, 200 and 330

Type	H min. [mm]	H max. [mm]	S max. [mm]	Support load* at		ØD [mm]	End plates**					
				[kN] 4 bar	[mm] H		Type	ØA	E	F	L	M
40-1	60	100	40	1,5	100	160	1	90	20,0	10,0	G 1/8	M 8 × 15
100-1	60	130	70	4,0	115	225	2	114	44,5	-	G 1/4	M 8 × 15
200-1	60	125	65	8,0	110	265	3	161	89,0	38,1	G 3/4	M 8 × 15
330-1	60	140	80	15,0	120	340	3	228	157,5	73,0	G 3/4	M 8 × 15
80-3B	100 with 10 kg load	-	50 at 4 bar	0,5 at max 4 bar	150 with 10 kg load	95	3B	78	36,0	-	G 1/4	M 6

\* Support load and stroke are interdependent values.

\*\* The end plate is equipped with a compressed air port.

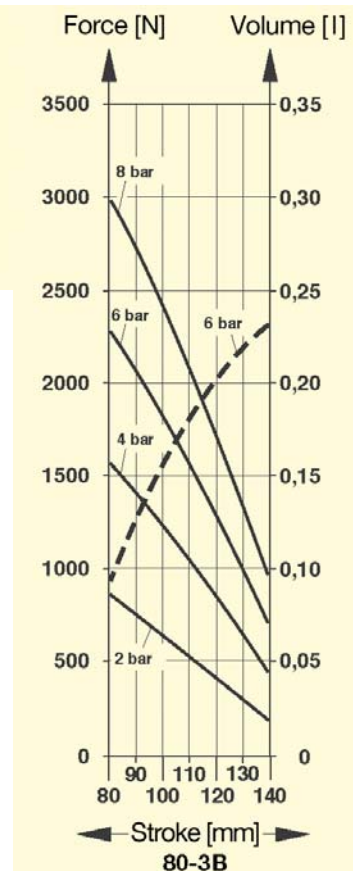
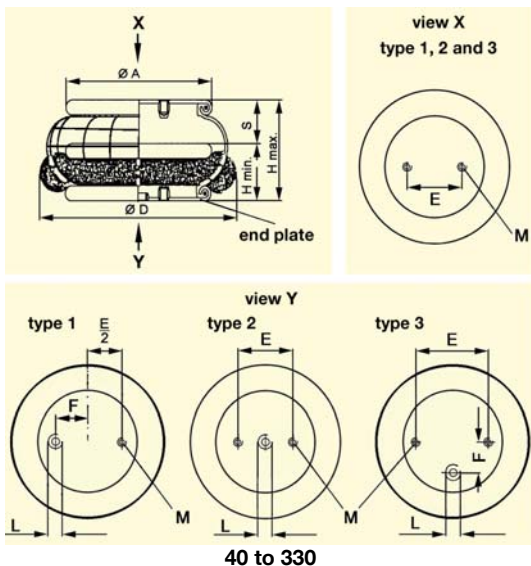
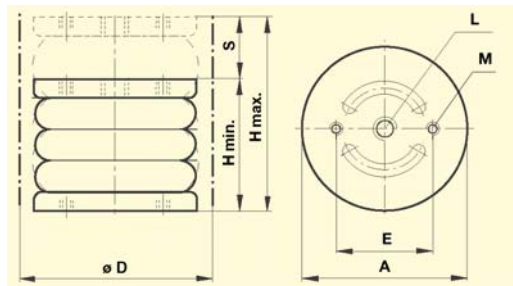

The pneumatic spring bellows 40, 100, 200 and 330 are made of reinforced elastomer multilayers. The steel end plates are securely joined to the bellow walls by means of beading and are pressure-tight. A lateral displacement of up to max. 10 mm is permissible. Up to 30° inclination of the end plates is possible, provided H min. and H max. are observed.

The walls of the spring bellows 80 consist of high quality elastomer layers and are reinforced by two layers of nylon cord. The end plates are securely joined to the bellow walls by means of beading and are pressure-tight. Up to 25° inclination of the end plates is possible, provided H min. and H max. are observed.

### Permissible operating conditions

#### Drive medium:

Compressed air or nitrogen

#### Operating pressure:

4 bar to 6 bar

#### Ambient temperature:

-40°C to 70°C

NetterVibration offers the accessories required for the mounting, installation, control and monitoring of vibrators and impactors.

### Netter provides solutions.

Consult our experienced application technicians.

### Netter GmbH

#### Germany

Fritz-Ullmann-Str. 9  
55252 Mainz-Kastel  
Tel. +49 6134 2901-0

#### Poland

Al. W. Korfantego 195/17  
40-153 Katowice  
Tel. +48 32 2050947

#### Switzerland

Erlenweg 4  
4310 Rheinfelden  
Tel. +41 61 8316200

#### Spain

Errota Kalea 8  
20150 Villabona-Guipúzcoa  
Tel. +34 943 694 994

www.NetterVibration.com  
info@NetterVibration.com



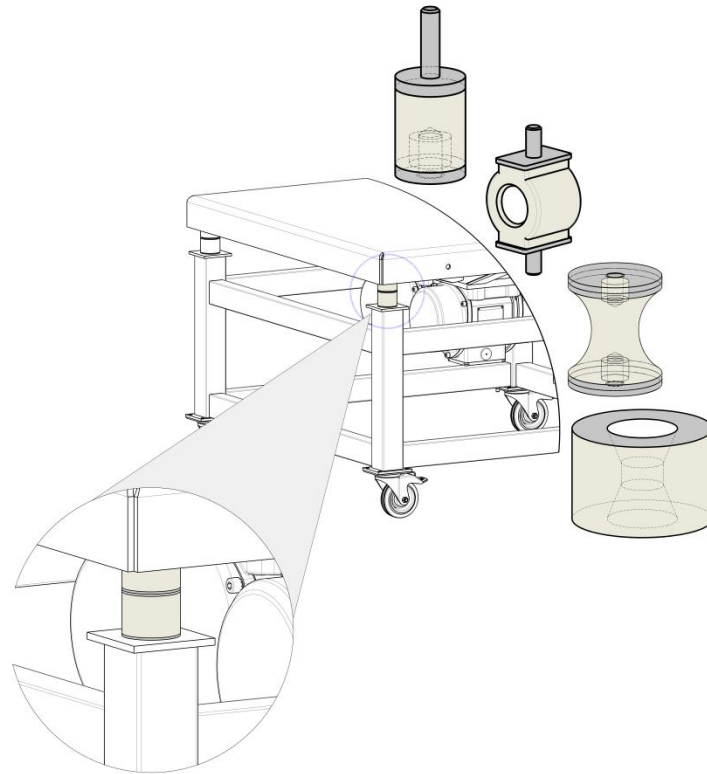

## Rubber elements, anti-vibration elements Series NRE, NTE, NOF and NAP

- **Reliable vibration isolation of mechanical components**
- High static and dynamic load capacity
- Elastic support of vibration equipment
- Good insulation and damping properties due to low Shore-hardness



Version A



Version B

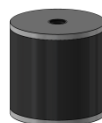

Version C



Version D



Version E

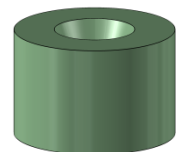

Version F



**NetterVibration**



**Rubber elements, anti-vibration elements**  
Series NRE, NTE, NOF und NAP

Typ	D [mm]	H [mm]	G	Version	L1 [mm]	L2 [mm]	Hardness [°sh]	Max. compression [mm]	Max. stat. load capacity [kg]
<b>Round elements</b>									
NRE 15/25	15	25	M4	B	4	15	43	3,4	8
NRE 20/30	20	30	M6	B	5	18	45	3,9	16
NRE 25/30	25	30	M6	B	6	18	43	3,9	20
NRE 30/40	30	40	M8	B	9,5	21	45	5,1	31
NRE 40/40	40	40	M8	B	8	23	43	5,4	60
NRE 40/40	40	40	M8	C	8	-	43	5,4	53
NRE 50/40	50	40	M10	B	10	28	43	5,1	86
NRE 50/40	50	40	M10	C	10	-	43	5,1	100
NRE 50/50	50	50	M10	B	10	28	43	6,6	95
NRE 50/50	50	50	M10	C	10	-	43	6,6	80
NRE 70/45	70	45	M10	C	10	-	43	5,9	190
NRE 75/55	75	55	M12	C	12	-	43	7,4	225
NRE 100/55	100	55	M16	C	16	-	43	7,1	465
NRE 150/55	150	55	M16	C	16	-	43	6,8	1.480
NRE 200/100	200	100	M20	C	17,5	-	55	13	2.360
<b>Waist elements</b>									
NTE 40/50	40	48	M8	C	8	-	57	6,6	33
<b>O-shaped elements</b>									
NOF 22/30	22	30	M5	A	-	10,0	60	Z-direction: 3 X-direct.: 12	5 4
NOF 28/38	28	38	M6	A	-	9,5	60	Z-direction: 3 X-direct.: 14	10 16
<b>Bump stops</b>									
NAP 30/15	30	15	M8	D	-	20	45	1,4	25
NAP 30/30	30	30	M8	D	-	20	45	4,5	40
NAP 40/20	40	20	M8	E	-	-	55	3,0	70

Type	D [mm]	H [mm]	G [mm]	Version	Min. compression [mm]	Min. stat. load capacity [kg]	Max. compression [mm]	Max. stat. load capacity [kg]
<b>Anti-vibration elements</b>								
NRE 100/100s	100	100	32	F	5	135	40	1.090
NRE 150/150be	150	100	45	F	5	660	25	3.310
NRE 150/100g	150	100	45	F	5	335	15	1.010
NRE 150/100hg	150	100	45	F	5	390	25	1.960
NRE 150/100s	150	100	45	F	5	800	25	4.000
NRE 200/170be	200	170	72	F	5	400	25	2.010
NRE 200/170hbl	200	170	72	F	5	240	25	1.200
NRE 250/250be	250	250	51	F	5	370	50	3.720
NRE 250/250hbl	250	250	51	F	5	285	50	2.830

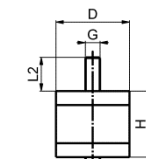

Version A

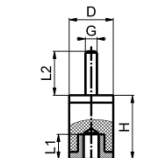

Version B

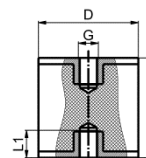

Version C

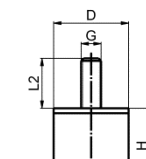

Version D

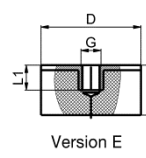

Version E

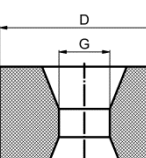

Version F

O-shaped elements (version A)

Waist elements (version C)

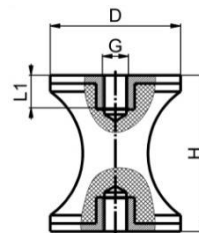
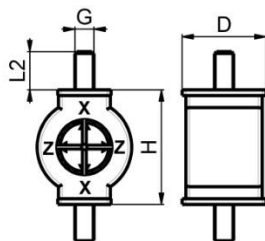

**Applications:**

Rubber buffers are used for the vibration isolation of mechanical components and the support of vibration equipment.

Compression, shear, torsional stresses or a combination of these can be exerted on rubber elements. The elements isolate and damp very well due to their low Shore-hardness when used properly.

NetterVibration offers the accessories required for the mounting, installation, control and monitoring of vibrators and pneumatic impactors.

**Netter provides solutions. Consult our experienced application technicians.**

**Netter GmbH**

**Germany**  
Fritz-Ullmann-Str. 9  
55252 Mainz-Kastel  
Tel. +49 6134 2901-0

**Poland**  
Al. W. Korfantego 195/17  
40-153 Katowice  
Tel. +48 32 2050947

**Switzerland**  
Erlenweg 4  
4310 Rheinfelden  
Tel. +41 61 8316200

**Spain**  
Errota Kalea 8  
20150 Villabona-Guipúzcoa  
Tel. +34 943 694 994

www.**NetterVibration.com**  
Info@**NetterVibration.com**

12/2017 Subject to change without notice

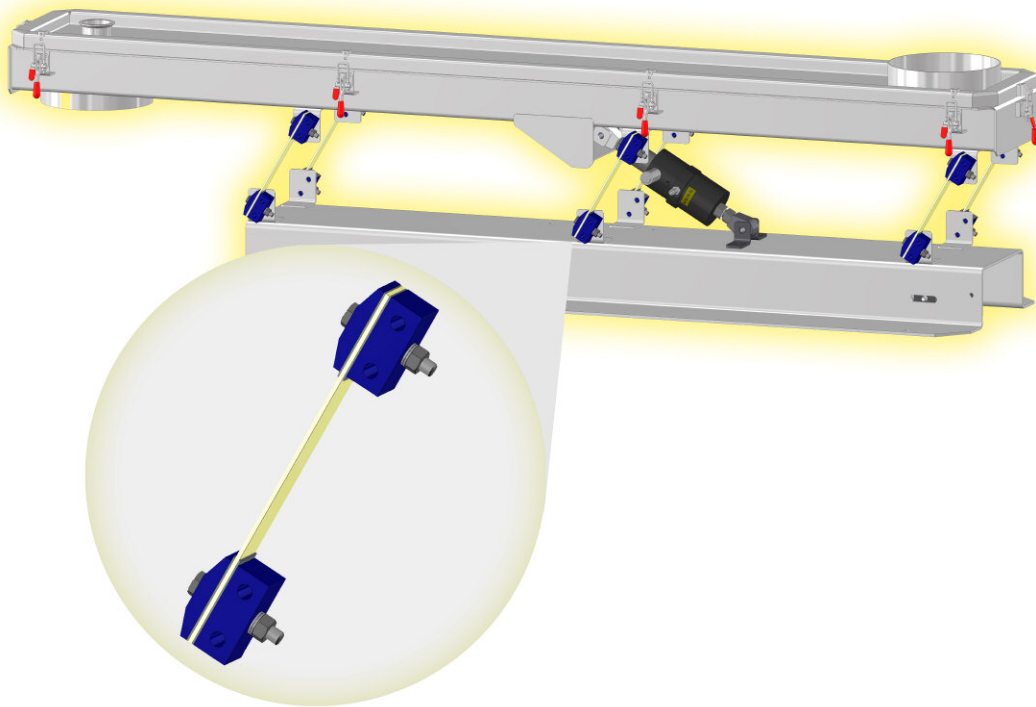

50

## Fibreglass Epoxy Resin Blade Spring Combinations Series BA - EC

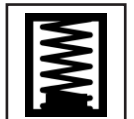

- **Quick and simple conveyor system construction**
- Suitable for conveyor troughs with a low tare weight
- Large variety of possible combinations
- High conveying speed or large amplitude possible



BA to BE

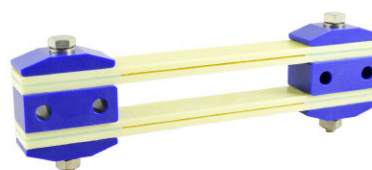

EA to EC



## Fibreglass Epoxy Resin Blade Springs Combinations Series BA - EC

Type	Resonance weight [kg]		Blade spring combinations comprising: 2 x inner block, 2 x screw, nut, lock, 2 x outer block and in addition	Type of spring	Dimensions [mm]	Free length [mm]	Max. amplitude [mm]
	at 400 min <sup>-1</sup>	at 600 min <sup>-1</sup>					
BA	2.30	1.02	1 x blade spring	NJ	2.5 x 25 x 220	120	19
BB	3.87	1.72		NK	3.0 x 25 x 220	120	16
BC	8.28	3.68		NL	4.0 x 25 x 220	120	12
BD	10.29	4.57		NM	5.0 x 25 x 220	160	19
BE	11.15	4.96		NN	6.0 x 25 x 220	160	14
CA	5.48	2.44		2 x intermediate layer, 2 x blade spring	NJ	The number of blade springs required is given by the formula:  weight of trough/resonance weight = number of springs required  The natural resonance of a blade spring depends on its support weight. Therefore, the natural resonance is given for all spring types.	
CB	7.88	3.50	NK				
CC	16.28	7.24	NL				
DA	4.71	2.09	2 x blade spring 2 x outer block	NJ			
DB	8.45	3.76		NK			
DC	17.02	7.56		NL			
DE	29.84	13.26	2x intermediate layer 3 x blade spring 2 x outer block	NN			
FA	7.17	3.17		NJ			
FB	12.13	5.39		NK			
FC	25.41	11.29	NL				
EA	9.57	4.25	4 x intermediate layer 4 x blade spring 2 x outer block	NJ			
EB	16.63	7.39		NK			
EC	37.87	16.83		NL			

	<b>blade spring combination BA to BE</b>	
	<b>blade spring combination CA to CC</b>	
	<b>blade spring combination DA to DE</b>	
	<b>blade spring combination FA to FC</b>	
	<b>blade spring combination EA to EC</b>	

### Application areas:

Conveyor systems with a low tare weight can be quickly and easily built with blade spring combinations. These include, among other things, transport chutes, conveyor troughs for dosing, and sieves. The low tare weight of the conveyor system saves energy. Resonance conveyor systems with large amplitudes are suitable for drying or airing bulk materials.

### Design and function:

The arrangement of the blade springs may be linear or circular. In a linear arrangement, the distance between the positions should not exceed 1 m. The attachment of the vibrator to the conveyor system is variable due to the steering duct of the blade springs.

### Special features:

Optionally available are FDA-compliant, blue blade springs made of fibreglass with blue clamping blocks, which ensure good detectability in the food industry. Black blade spring combinations made of carbon fibres enable use in potentially explosive areas according to the ATEX directive.

### Ambient temperature:

Maximum 70 °C.

**NetterVibration** offers the accessories required for the mounting, installation, control and monitoring of conveyor systems.

### Netter provides solutions.

**Consult our experienced application technicians.**

### Netter GmbH

#### Germany

Fritz-Ullmann-Str. 9  
55252 Mainz-Kastel  
Tel. +49 6134 2901-0

#### Poland

Al. W. Korfanteo 195/17  
40-153 Katowice  
Tel. +48 32 2050947

#### Switzerland

Erlenweg 4  
4310 Rheinfelden  
Tel. +41 61 8316200

#### Spain

Errota Kalea 8  
20150 Villabona-Guipúzcoa  
Tel. +34 943 694 994

www.**NetterVibration**.com  
info@**NetterVibration**.com

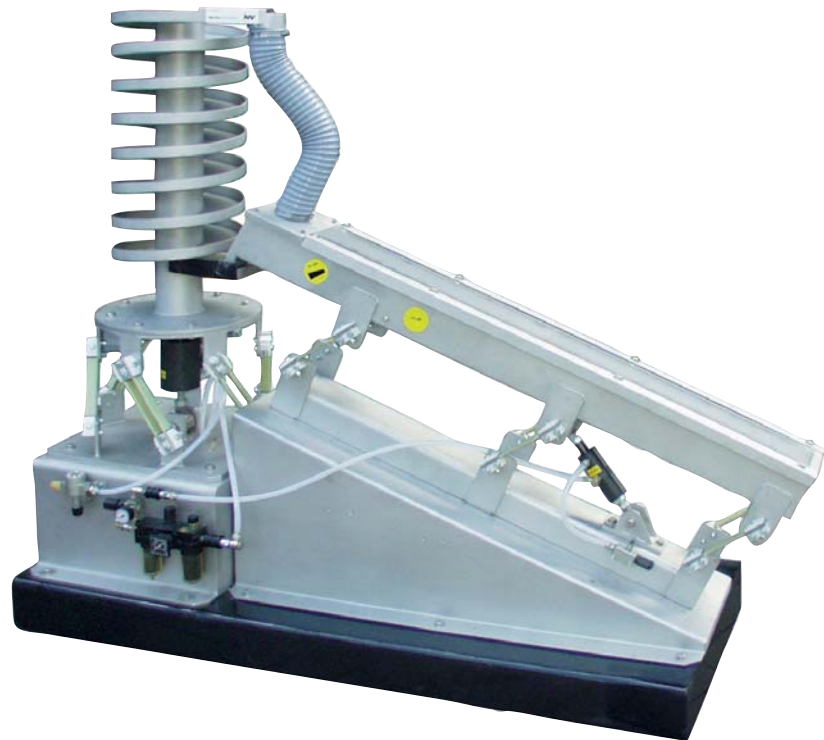

## Netter Resonance Conveyor System Series *FlexiLink*



- High conveying performance by use of spring resonance
- Low air consumption
- Immediate starting and stopping
- Low unit weight



FlexiLink Element



NTK



Conveyor with FlexiLink and NTK





## Netter Resonance Conveyor System Series *FlexiLink*

Netter resonance conveyor systems in the FlexiLink series consist of:

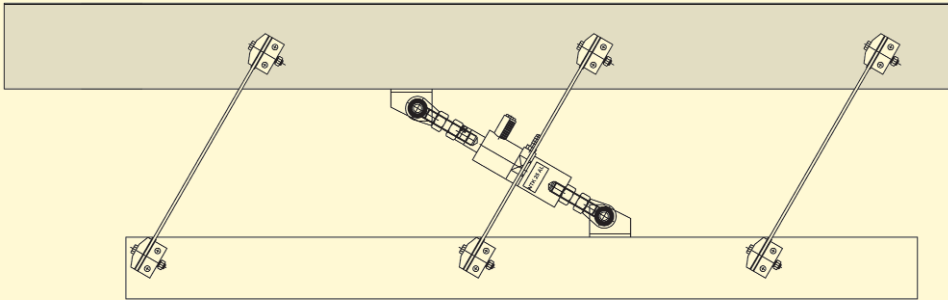

A conveyor trough, manufactured either by the client or as per the client's requirements

blade springs,

a pneumatic linear vibrator series NTK with the **FlexiLink** connecting element

and the counter-weight (frame/floor)

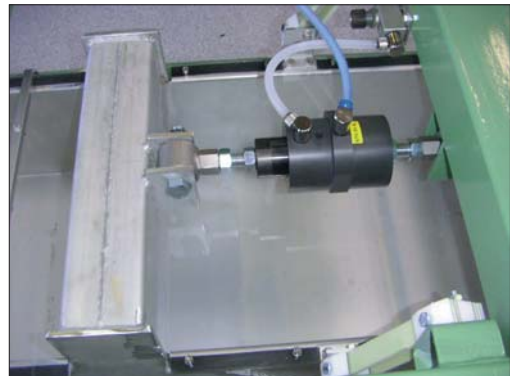

### Applications

Conveyor systems of the **FlexiLink** series serve to convey bulk material efficiently and gently.

### Design and functioning principle

The feeder system consists of a pneumatic linear vibrator of series NTK, blade springs and the **FlexiLink** connecting element.

This system uses the natural resonance of the springs in order to convey bulk materials. Once the trough starts to vibrate at the resonance frequency, very little additional energy is required to maintain the vibration. Even with varying loads, the trough continues to vibrate in resonance.

The amplitude can be adjusted by means of an optional exhaust throttle.

In addition to driving classic feeder troughs, the **FlexiLink** system can also be used to drive spiral feeders. The blade springs are then arranged in a circle in order to

accommodate the spiral feeder. In addition to the standard versions, customized variants of the **FlexiLink** series can be furnished at a special price.

### Permissible operating conditions: Drive Medium:

Compressed air or nitrogen (filter ≤

5 µm), preferably with oil mist

### Operating pressure:

2 bar to 6 bar

### Ambient temperature:

5°C to 60°C

**NetterVibration** offers the accessories required for the mounting, installation, control and monitoring of vibrators and impactors.

**Netter provides solutions.**

**Consult our experienced application technicians.**

### Netter GmbH

#### Germany

Fritz-Ullmann-Str. 9  
55252 Mainz-Kastel  
Tel. +49 6134 2901-0

#### Poland

Al. W. Korfantego 195/17  
40-153 Katowice  
Tel. +48 32 2050947

#### Switzerland

Erlenweg 4  
4310 Rheinfelden  
Tel. +41 61 8316200

#### Spain

Errota Kalea 8  
20150 Villabona-Guipúzcoa  
Tel. +34 943 694 994

[www.NetterVibration.com](http://www.NetterVibration.com)  
info@NetterVibration.com





## Netter Sound Protection Hood



- Sound reduction
- Insulation of the sound level
- Complete isolation of the source of sound

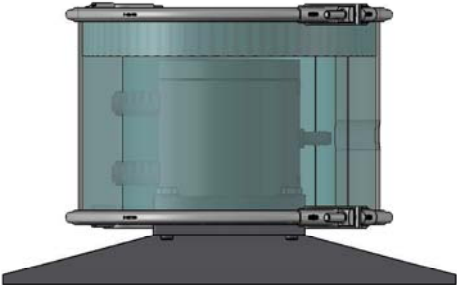

Sound protection hood for NHK with weld-on bracket

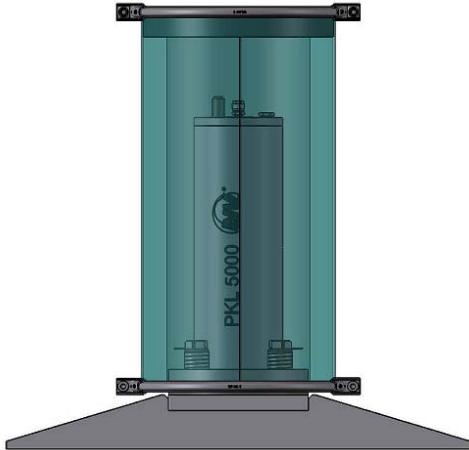

Sound protection hood for PKL 2100 or PKL 5000 with weld-on bracket



## Netter Sound Protection Hood

Vibrator or impactor type		Sound protection hood type	max. Diameter [mm]	max. Height [mm]
PKL 190	NTS 50/01	Sound protection hood 200/280	265	302
PKL 450	NTS 75/01			
PKL 740	NTS 100/01			
PKL 2100		Sound protection hood 250/500	315	508
PKL 5000				
NTS 50/04	NTS 70/02	Sound protection hood 300/201	365	226
NTS 54/02				
NHK 50-04		Sound protection hood 302/500	365	700

Example for mounting an NHK with sound protection hood:

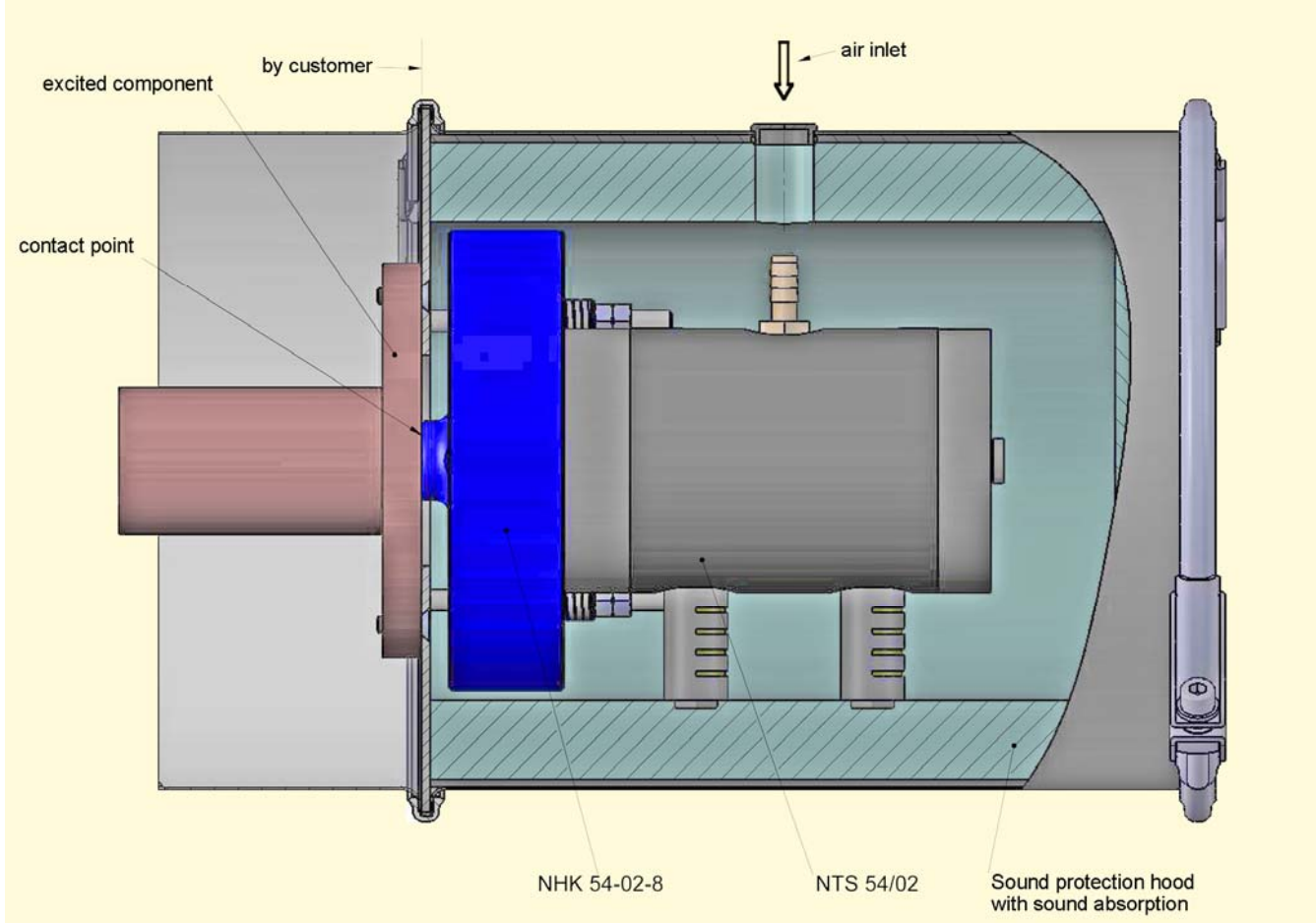

### Applications

Sound protection hoods for vibrators and impactors are intended to reduce the sound effectively. To reduce the sound effectively, the impacted plates have also been insulated (eg thermal insulation).



The lining consists of acoustic enclosures  
 - one noise-absorbent mat and  
 - one absorption foam mat.

**Operating temperature:**  
 max. 100°C (HT version on request).

**Material:**  
 Stainless steel sheet. (Other materials on request).

We pleased to offer sound protection hoods for other vibrators and impactors.

**NetterVibration** offers the accessories required for the mounting, installation, control and monitoring of vibrators and impactors.

**Netter provides solutions. Consult our experienced application technicians.**

### Netter GmbH

**Germany**  
 Fritz-Ullmann-Str. 9  
 55252 Mainz-Kastel  
 Tel. +49 6134 2901-0

**Poland**  
 Al. W. Korfanteo 195/17  
 40-153 Katowice  
 Tel. +48 32 2050947

**Switzerland**  
 Erlenweg 4  
 4310 Rheinfelden  
 Tel. +41 61 8316200

**Spain**  
 Errota Kalea 8  
 20150 Villabona-Guipúzcoa  
 Tel. +34 943 694 994

www.**NetterVibration.com**  
 info@**NetterVibration.com**