

These operating instructions apply for:

***DosyPack*** 4  
***DosyPack*** 25  
***DosyPack*** 40  
***DosyPack*** 56  
***DosyPack*** 80



### Important note:

Before use of the Netter dosing station series ***DosyPack*** read this operating instruction carefully and store afterwards.

Netter GmbH does not assume liability for damage to property and persons if the product has been technically modified or if the notes and regulations of these operating instructions have not been observed.

This documentation is copyrighted. All rights, e.g. for translation into other languages, reprinting and copying of these operating instructions or parts hereof remain strictly reserved.

# Contents





1	GENERAL NOTES	3
2	TECHNICAL DATA	3
3	DESIGN AND FUNCTION	4
4	SAFETY	5
5	TRANSPORT AND STORAGE	5
6	INSTALLATION	6
7	START-UP / OPERATION	6
8	SERVICE / MAINTENANCE	7
9	TROUBLESHOOTING	7
10	SPARE PARTS	8
11	APPENDIX	8
11.1	Accessories	8
11.2	Disposal	8
11.3	Enclosures	8

## Scope of Delivery



Check the packaging for possible signs of transport damage. In the event of damage to the packaging, check that the contents are complete and undamaged. If there is any damage, inform the shipping agent. Compare the scope of the delivery with the delivery note.

The following instruction and warning symbols are used in these operating instructions.

	Note on important procedures		Warning of a danger spot
	Important note on procedures to be especially observed		Environmentally friendly disposal
	Do not touch		

## 1 General Notes

Netter series **DosyPack** dosing stations comply with the EC machine directive 2006/42/EC. Standards DIN EN ISO 12100, parts 1 and 2 have been particularly observed.

The dosing stations use a conveyor trough to gently and evenly convey bulk material from a hopper.

The station is driven by a pneumatic linear vibrator.

Pneumatic vibrators can be regulated very well and stop immediately when switched off. The feed rate can therefore be exactly adjusted and conveying stops instantly (no running on) when the vibrator is switched off.

General areas of application are:

Fast and exact dosing of all types of bulk material or as feeders for optical sorting facilities. Gentle dosing is possible for especially sensitive products.

All product-carrying parts of the **DosyPacks** are quick and easy to clean. This allows applications even under the strict hygienic conditions demanded by the chemical, pharmaceutical and food industries.

The drive medium is clean (filtered) lubricated compressed air or nitrogen.

Special Features:

- High conveyor capability
- Gentle and even dosing
- Adjustable coarse or fine flow
- Exact dosing
- All product-carrying parts made of stainless steel 1.4301
- High surface quality
- Fast and easy to clean

## 2 Technical Data

### Drive Medium:

Compressed air or nitrogen, filtered and lubricated: filter ≤ 5 µm

Oil-free operation: filter ≤ 0.01 µm

**Unfiltered compressed air will lead to breakdown of the vibrators.**

### Operating pressure:

2 bar to 6 bar \*

The operating pressures must not be exceeded or fallen short of.

### Ambient Temperature:

5°C bis 60° C\*

The operating temperatures must not be exceeded or fallen short of.

### Lubrication:

Lubricated compressed air is recommended in order to protect the equipment, the service life can be significantly increased.

Series NTK and NTS pneumatic linear vibrators can be operated without oil (filter ≤ 0.01 µm). (Exception: with dried air or under extreme ambient conditions).

\*) Higher operating pressures and temperatures are only possible after consultation and with written permission from the Netter GmbH application technicians.



Product Characteristics			Conveyor Capability		Noise Level [dB(A)]
Example	Bulk Density [kg/ dm <sup>3</sup> ]	Grain Size [mm]	<b>DosyPack</b> 4	<b>DosyPack</b> 25 to 80	
Sand	1.54	0 - 1	0 - 20	0 - 260	56 - 75
Granules	0.70	1 - 3		0 - 150	56 - 75
Plastic caps	0.20	∅ 10		0 - 25	56 - 73

The technical data relate to the examples given and may vary, depending on the product.

## Dimensions

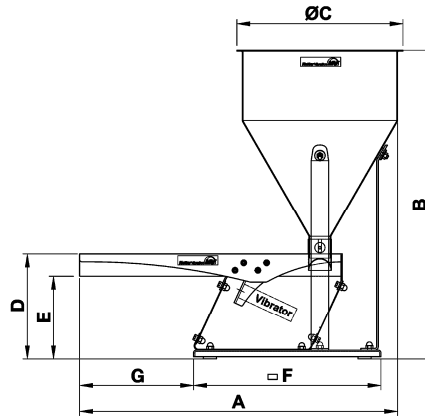

Typ	A	B	ØC	D	E	□F	G	V (Container volume)	Weight
	[mm]	[mm]	[mm]	[mm]	[mm]	[mm]	[mm]	[l]	[kg]
<b>DosyPack 4</b>	420	480	200	190	175	290 x 150	105	4	5,5
<b>DosyPack 25</b>	729	710	381	241	190,5	430 x 280	261	25	15,0
<b>DosyPack 40</b>	729	860	381	241	190,5	430 x 280	261	40	16,8
<b>DosyPack 56</b>	805	844	533	241	190,5	430 x 280	261	56	26,3
<b>DosyPack 80</b>	805	994	533	241	190,5	430 x 280	261	80	29,5

## 3 Design and Function

The dosing stations consist essentially of a hopper **1** and a conveyor system **PowerPack 3**.

**PowerPacks 3** consist of a conveyor trough mounted on leaf springs and work using a Netter series NTS or NTK pneumatic linear vibrator **4**.



The flow is pre-dosed using a dosing adapter **2** on the outlet port of the hopper **1**.

The exact flow rate is determined by regulation of the frequency and amplitude of vibration. These can each be adjusted independently.

The frequency can be adjusted using the pressure regulator, in the optional maintenance unit **6**.

The conveyor speed (vibration amplitude) can be adjusted using an optional throttle in the air exhaust.

A directional valve **5** should be used for activation, in order to guarantee correct start-up. This valve also ensures an immediate standstill when the device is switched off (not included in scope of delivery).

The optional maintenance unit **6** supplies the vibrators with clean (lubricated) compressed air.



- 1 Hopper
- 2 Dosing adapter
- 3 Conveyor system **PowerPack**
- 4 Pneumatic linear vibrator (NTK or NTS)
- 5 Directional valve(optional)
- 6 Maintenance unit (optional)

## 4 Safety



Modifications to the devices can alter the characteristics of the dosing stations or destroy the devices, and result in the rejection of all warranty claims.

### Permissible Operating Conditions:

#### Drive Medium:

Compressed air or nitrogen, filtered and lubricated: filter  $\leq 5 \mu\text{m}$   
Oil-free operation: filter  $\leq 0.01 \mu\text{m}$

**Unfiltered compressed air will lead to breakdown of the vibrators.**

#### Operating pressure:

2 bar to 6 bar\*

The operating pressures must not be exceeded or fallen short of.



#### Ambient Temperature:

5°C to 60° C\*

The operating temperatures must not be exceeded or fallen short of.

#### Lubrication:

Lubricated compressed air is recommended in order to protect the equipment, the service life can be significantly increased.

Series NTK and NTS pneumatic linear vibrators can be operated without oil (filter  $\leq 0.01 \mu\text{m}$ ). (Exception: with dried air or under extreme ambient conditions).



**DosyPacks** operate on compressed air.

Ensure that the compressed air supply is shut off during installation. Disconnect the air supply before starting work on the vibrators or supply lines. All hose connections must be tightly fastened before starting operation. If a pressurized hose becomes loose it can cause injury.



**It is prohibited to touch the *PowerPack* and the pneumatic linear vibrator during the operation.**



Series **DosyPack** dosing stations must be mounted on a clean, flat surface and secured against falling over or falling down.

## 5 Transport and Storage



Check the packaging for possible signs of transport damage.

In the event of damage to the packaging, check that the contents are complete and undamaged. If there is any damage, inform the shipping agent.

The vibrators are packed ready-to-install.

When transporting the dosing stations, care should be taken not to subject them to severe impacts or vibrations.

The units should be stored in a clean, dry environment.



The storage temperature should be between -40 and +60 °C. (This does not apply to the operating temperature; compare with chapter 4 “SAFETY – Permissible Operating Conditions”).

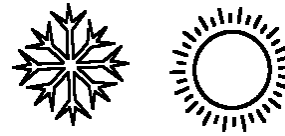

## 6 Installation



The safety advice in chapter 4 and the accident prevention regulations must be strictly observed during installation!

The system installation must be carried out in accordance with the familiar local regulations.



Series **DosyPack** dosing stations must be mounted on a clean, flat surface and secured against falling over or falling down.

### Standard Installation

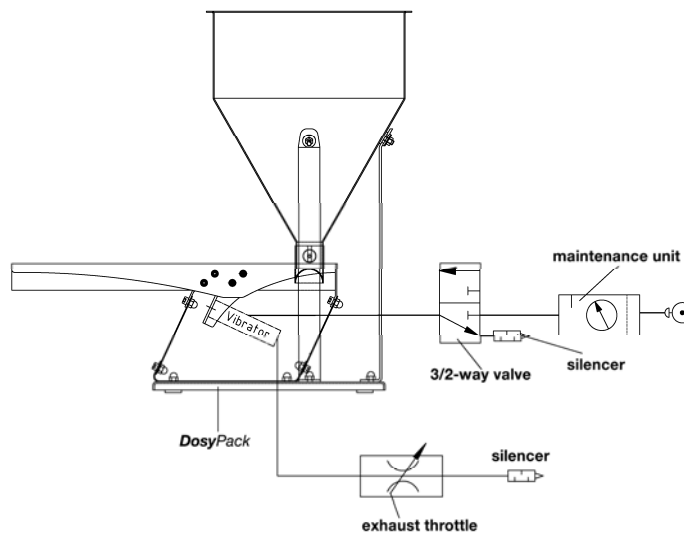

### Checklist for Installation:

- 1) Mount and fasten the device on a clean, flat surface.
- 2) Mount maintenance unit, valve, supply line, silencer.
- 3) Mount bellows, if necessary (NTK: dust, danger of jamming).
- 4) Mount additional mass (vibration mass) to piston or housing, if necessary (NTK).
- 5) Are the fastening screws secured? Check!
- 6) Is the device secured against falling down?

## 7 Start-Up / Operation



Please observe the safety advice in chapter 4 when starting up the device.

A directional valve **5** should be used for activation.

The bulk material in the hopper is directed onto the conveyor trough **3** via the dosing adapter **2**.

The height of the dosing adapter **2** is adjustable, whereby the flow rate is roughly regulated.

The conveyor trough **3** transports the bulk material gently to the filling point.

The frequency can be adjusted precisely using the pressure regulator, in the optional maintenance unit **6**.

The conveyor speed (vibration amplitude) can be adjusted using an optional throttle in the air exhaust.



The use of an upstream oil mister is compulsory when using dried compressed air. The oil mister must be filled with acid- and resin-free pneumatic oil, ISO viscosity class according to DIN 51519, VG 5 to VG 15.

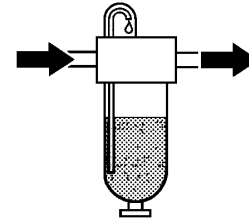

### Checklist for Start-Up:



- 1). Check the hose connections before switching on.
- 2). Set the desired frequency on the pressure regulator.
- 3). Set the required vibration amplitude by throttling the exhaust air.
- 4). Adjust the mist lubricator, if available.
- 5). Screwed connections and compressed air supply lines should be re-tightened after 1 hour of operation (after initial start-up) and then checked at regular intervals (generally once per month) and tightened, if necessary

## 8 Service / Maintenance



**Please observe the safety regulations in chapter 4 when servicing the device.**

The optional maintenance unit supplies the vibrators with clean (lubricated) compressed air. The service intervals depend essentially on the cleanliness of your drive medium.

### Mist lubricator:

For devices with an upstream lubricator, it is necessary to ensure that the lubricator works correctly. (does oil content fall? Number of drops/min?). Refill oil.

### Filter:

Empty the filter as required, clean the filter insert (wash out).

### Cleaning

**DosyPacks** can be externally cleaned using pressurized water, provided a hose is used to discharge the air or the air

outlet ports are closed. Pressurized water must not enter the vibrator via the silencer.

Series NTK pneumatic linear vibrators should be activated briefly after cleaning (do not direct pressurized water onto the gap between the piston and the housing).

### Soiling:

A coating may form on devices operated without lubrication, which can limit the vibrator.

Additional advice can be found in chapter 9 "troubleshooting" and in the operating instructions for the vibrators.

## 9 Troubleshooting

Fault	Possible Cause	Remedy
Device does not start	Silencer	Clean silencer
	Compressed air supply	Check pressure on device! Sufficient pressure available? Check valve.
	Discharged air over-throttled	Open throttle. Check silencer (adequate air passage?).
	Warping from installation	Check whether mounting surface is flat.
Rattling	Screws loose	Check the fastening screws
Power drop	Lack of lubrication	Check function of oil mister.
	Device soiled	Disassemble, remove coating.
	Wear	Check vibrator for visible signs of wear (if wear is evident, send device in!).
	Pressure too low	Check pressure at device inlet port (!) during operation. Increase pressure, if necessary. Hose cross-sections OK?

## 10 Spare Parts

Please provide the following details when ordering parts (e.g. fuses):

1. Type of device
2. Description and position of replacement part
3. Quantity required

## 11 Appendix

### 11.1 Accessories

The following accessories are available for **DosyPack** dosing stations (upon request):

Description	Remark
Vibration masses SM	For linear vibrators NTK in various sizes
Bellows NFB	For linear vibrators NTK.
Hose material and fittings	For supply and discharge of compressed air in various qualities and dimensions.
3/2-way valves	For electric, pneumatic and manual control
Throttle valves	For regulation of rotational speed; manual, pneumatic or electronic regulation (for remote control)
Maintenance units	Filter-regulator-oil mister or filter regulator (for oil-free NTK and NTS)
Duty/pause controls	Electric or pneumatic, for interval operation
<b>Special versions:</b>	Vibrators are available for extreme temperature areas, in complete stainless steel versions for applications in aggressive environments, for higher frequency ranges (HF versions). Information available upon request

### 11.2 Disposal

#### Material Specifications:

All parts of the dosing stations can be recycled:

- Vibrators: ⇒ see operating instructions NTK or NTS
- Maintenance unit: ⇒ see technical data sheet
- Screws: ⇒ stainless steel
- All product-carrying parts: ⇒ stainless steel



All units can be disposed of through Netter GmbH. The applicable disposal prices are available upon request.

### 11.3 Enclosures

#### Enclosure(s):

Declaration of conformity



**Additional information available upon request:  
Brochure No. 44 and many more.**