



NetterVibration

Operating instructions for
Netter pneumatic internal vibrators
Series NVV



April 2021
No. 1991
Page 1/19

These operating instructions apply to:

NVV 28
NVV 35
NVV 45
NVV 55

NVV 65
NVV 75
NVV 85
NVV 100
NVV 150



Contents

1	General information	3
2	Safety	5
3	Technical data	7
4	Design and function	9
5	Transport and storage	10
6	Start-up and operation	11
7	Maintenance and servicing	13
8	Troubleshooting	15
9	Spare parts and accessories	16
10	Disposal	18
11	Annex	19

Scope of delivery

Please refer to the delivery note for the scope of delivery.
Check the packaging for possible transport damage. In the event of damage to the packaging, check the contents for completeness and possible damage. Inform the carrier in the case of damage.

Designation

The pneumatic internal vibrators of the series NVV are hereafter referred to as "NVV".

Version of document

Document no.	1991
Version no.	1
Date of issue	April 2021

1 General information

Use and storage	Before installing the NVV read these instructions carefully. It is the basis for any action when dealing with the NVV, and may be used for training purposes. The instructions should be subsequently stored at the operation site.
Target group	The target group for these instructions is technical staff, who have basic knowledge in pneumatics and mechanics. Only complying technical staff may work on the NVV. The NVV may only be installed, put into operation, maintained, troubleshot and disassembled by persons authorised by the operator.
Copyright	This documentation is protected by copyright. NetterVibration reserves all rights such as translations, reprinting and reproduction of the instructions, as well as parts thereof.
Limitation of liability	All technical information, data and instructions for installation, operation and maintenance in these instructions are based on the latest information available at the time of printing and take our past experience to the best of our knowledge into account. No claims can be derived from the information, illustrations and descriptions in these operating instructions. The manufacturer does not assume liability for damages resulting from: <ul style="list-style-type: none">• failure to observe the instructions,• improper use,• unauthorised repairs,• technical modifications,• use of non-permissible spare parts. Translations are made to the best of our knowledge. NetterVibration does not assume liability for translation errors, even if the translation was made by us or on our behalf. Only the original German text remains binding.
Directives / standards observed	The pneumatic internal vibrators of the series NVV comply with the EC Machinery Directive 2006/42/EC. In particular, the standard EN ISO 12100 has been observed.

Instruction and warning symbols

The following instruction and warning symbols are used in these instructions:

Personal injuries

⚠ DANGER	
	<p>indicates an immediate danger. Disregard of this notice will result in death or severe personal injuries.</p>

⚠ WARNING	
	<p>indicates a potential danger. Disregard of this notice can result in death or severe personal injuries.</p>

⚠ CAUTION	
	<p>indicates a potentially dangerous situation. Disregard of this notice can result in minor or moderate personal injuries.</p>

Material damages

NOTICE	
<p>indicates potential material damage. Disregard of this notice can result in material damage.</p>	

Notes

IMPORTANT	
<p>indicates actions, methods or notes that are not relative to safety, e.g. useful information and tips.</p>	

	<p>Environmentally safe disposal indicates the obligation of environmentally safe disposal.</p>
---	--

2 Safety

Intended use

The NVV are intended for generating radial vibrations.

NVV are used for compacting concrete or bulk materials, for cleaning or deaerating.

The NVV may also be used outdoors as well as in dusty and humid environment.

The NVV have to be submerged in bulk materials or in liquids.

Any other use is considered improper.

Qualification of qualified personnel

Installation, commissioning, maintenance and troubleshooting of the NVV may only be performed by authorised qualified personnel.

All handling of the NVV is the responsibility of the operator.

Falling parts

WARNING

Falling parts

The NVV can fall down during transport and operation. Falling parts lead to severe personal injuries.

- Wear suitable personal protective equipment.

Compressed air

WARNING

Compressed air

A loosened hose which is under pressure can lead to personal injuries.

- Screw the hose lines on carefully.
- Check the hose lines and connections after one hour of operation and thereafter regularly (generally monthly).
- Retighten the hose lines, if necessary.
- Ensure that the compressed air is disconnected from the supply lines during all work on the NVV.
- Prevent the NVV from being switched back on during all work.

Sound level

WARNING



Sound level

Near the NVV or in the vicinity of the constructions connected with the NVV, the sound pressure level may exceed 80 dB(A). The human ear can be permanently damaged by the high sound level.

- When working in the noise area, use ear protection if 80 dB(A) is exceeded.

Heavy parts

⚠ WARNING
Risk of injury while handling heavy parts

Risk of serious injury due to weight during transport and operation of the NVV.

- Observe the weight information in Chapter Technical data, from page 7 on.
- Wear suitable personal protective equipment.

Vibration energy

⚠ WARNING
Damage to health due to vibration energy

Vibrating of whole bodies or any parts of them will result in damage to health.

- During operation of the NVV, only touch/hold the hose outside a sufficient safety distance (of at least 1 m) to the vibrator's nosepiece.
- Never touch the vibrator's nosepiece during operation.
- Limit the exposure time, take breaks during operation and wear suitable personal protective equipment.
- Never stand or sit on the NVV during operation.

Hot surfaces

⚠ CAUTION
Risk of burns due to hot surfaces

NVV can strongly heat up during operation. Direct contact may cause burns.

- Do not touch the vibrator's nosepiece during operation or shortly after being switched off.
- Only operate the NVV within the permissible ambient temperature, according to chap. Technical data, page 7.

Oil mist

⚠ CAUTION
Health and environmental risk due to oil mist during preserving

Oil mist is harmful to human health and the environment. Oil mist can cause damage to the skin, the mucous membranes and the respiratory system.

- Avoid direct contact with oil mist.
- In order to preserve the NVV 150 before storage, wear suitable personal protective equipment.
- Take measures to avoid release of oil mist into the environment.

3 Technical data

Permissible operating conditions

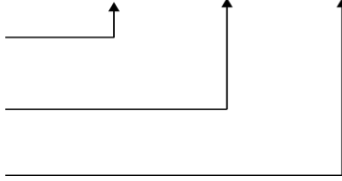
Drive medium	<p>NVV must be operated with filtered (filter $\leq 40 \mu\text{m}$), lubricated compressed air or lubricated nitrogen according to the following specification:</p> <p>ISO 8573-1 [x : 6 : 4]</p> <p>Filter $> 10 \mu\text{m}$</p> <p>Humidity, pressure dew point $\leq +10 \text{ }^\circ\text{C}$</p> <p>Total oil content $\leq 5 \text{ mg/m}^3$</p> 
Lubrication	<p>ISO viscosity class according to DIN ISO 3448, VG 15 or SAE viscosity class 5</p> <p>Fill the mist lubricator with acid- and resin-free compressed air oil.</p>
Ambient temperature*	-10 °C to 60 °C
Operating pressure	2.0 to 6.0 bar

* Higher temperatures are only permitted after consultation with and the written consent of application engineers from **NetterVibration**.

Performance data

For technical performance data, please refer to the brochure of the NVV. The technical performance data changes over the service life (wear and contamination).

Valves / hoses

NetterVibration recommends the following cross-sections:

Typ: NVV ...	Connection thread [inch]	Valve/ball valve [inch]	Minimum hosesize*
28, 35, 45, 55	3/4	G 1/4	DN 8
65, 75, 85		G 3/8	DN 10
100, 150		G 1/2	DN 12

* DN = diameter nominal (inner diameter)

Dimensions

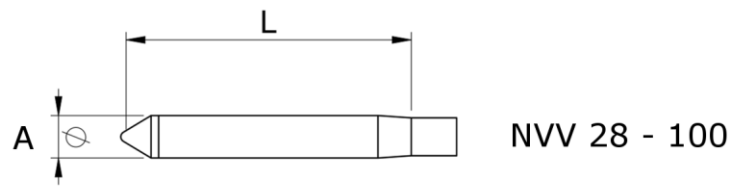
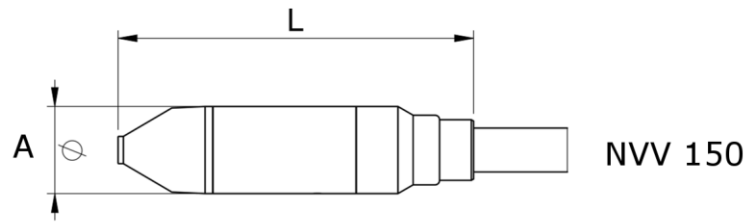

Type	Ø A [mm]	L [mm]	Total length* [mm]	Weight [kg]
NVV 28	28	234	2,584	4.5
NVV 35	35	278	2,628	6.0
NVV 45	45	285	2,635	8.0
NVV 55	55	316	2,666	9.0
NVV 65	65	327	2,677	10.0
NVV 75	75	366	2,716	15.0
NVV 85	85	395	2,745	19.0
NVV 100	100	395	2,745	23.0
NVV 150	150	508	1,400	38.0

* hose and handpiece included

4 Design and function

Design

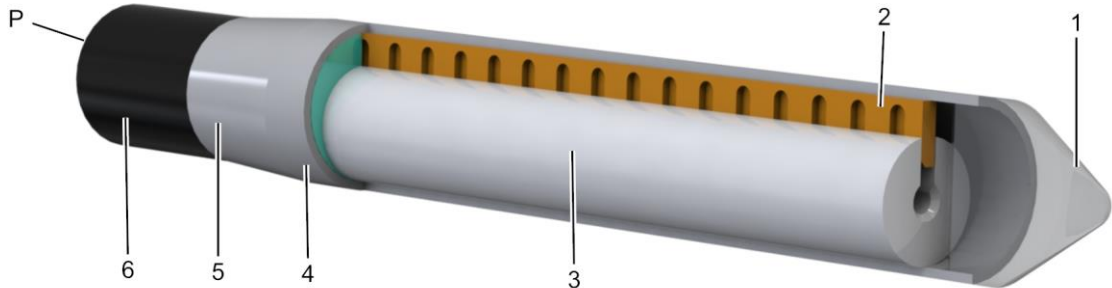

- | | | | |
|---|----------------------|---|----------------|
| 1 | Vibrator's nosepiece | 5 | Rear body |
| 2 | Vane | 6 | Hose |
| 3 | Rotor | P | Compressed air |
| 4 | Housing | | |

Function

The NVV generate radial vibrations, i.e. the vibrations act in all directions of a plane.

The frequency and therefore also the centrifugal force are infinitely variable via the operating pressure.

The vibration is produced by a rotor (3) that is eccentrically driven around the shaft.

The incoming compressed air (P) flows axially through the rotor by an internal bore and pushes the movable vane (2) radially against the housing (4). Through the channels of the vane the compressed air is fed into the housing where it fills the space to form an air chamber. The constant air supply increases the volume of the air chamber, causing the rotor to rotate within the housing. The compressed air chamber is continuously vented by discharging the air through the exhaust in the handpiece.

5 Transport and storage



Observe the safety instructions in chap. Safety, from page 5 on.

Transport conditions

Special conditions of transport are not required.

Packaging

The NVV are packed and ready for assembly. Accessories and add-on parts are delivered unmounted, unless otherwise agreed upon.

The packaging protects the NVV from transport damage. The packaging material has been selected from an environmentally safe and technically disposable point of view and is therefore recyclable.

The return of packaging to the material cycle conserves raw materials and reduces the amount of waste.

Storage conditions

- Store the NVV in a dry and clean environment.
- Protect the NVV from UV-exposures, weather and ozone.
- The storage temperature is between -20 °C and +60 °C.
- Hang the NVV 28 - 100 with the vibrator's nosepiece upwards and leave the manual valve open to drain out any water or dirt.
- Before storage of the NVV 150:
 1. Fill the housing of the NVV with approx. 60 ml of oil as shown in the permissible operating conditions (see chap. Technical data, page 7 "Lubrication").
 2. Run the NVV for 30 s.
Caution: Health and environmental risk due to escaping oil mist
 3. Hang the NVV with the vibrator's nosepiece upwards and the manual slide valve open to drain out any water or dirt.

6 Start-up and operation



Observe the safety instructions in chap. Safety, from page 5 on.

Permissible operating conditions

Please refer to chap. Technical data, page 7 for permissible operating conditions.

Standard installation

For all NVV, use a ball valve to shut off the main line and

- a maintenance unit with mist lubricator for NVV 150,
- a filter regulator for all other types of NVV (with an integrated mist lubricator).

Setting the frequency

Use the pressure control valve of the filter regulator/maintenance unit to set the operating frequency of the NVV.

By reducing the operating pressure, the centrifugal force is also reduced. At the same time the vibration amplitude remains almost constant.

Filling mist lubricator

Fill the lubricator body with approx. 60 ml of oil corresponding to the permissible operating conditions (see page 7; "Lubrication").

Notice: The NVV is ready for operation only after filling and correct functioning of the mist lubricator.

Initial lubrication

Before initial start-up, also pour 4-6 drops of oil onto the sieve of the claw coupling of the NVV.

Procedure

When starting-up the NVV carry out the following steps in succession:

1. Close the ball valve.
2. Close the manual (slide) valve of the NVV. For NVV 28 - 100, turn the manual valve clockwise while looking at the claw coupling.
3. Connect the claw coupling.
4. Open the ball valve.
5. Open the manual (slide) valve, for NVV 28 - 100 by turning it anti-clockwise.

Tap to start

IMPORTANT

If the NVV does not start, the vibrator's nosepiece should be briefly tapped onto a firm surface.



**Checklist
start-up**

Check that the following steps have been carried out:

Screw connections checked before start-up?

Use of ear protection ensured?

Ball valve, filter regulator/maintenance unit and supply line installed?

Desired frequency set on pressure control valve?

Mist lubricator filled?

After one hour of operation:

Hose supply connections checked, retightened, if necessary?

Then follow the maintenance plan.

After four hours of operation:

Mist lubricator refilled?

Then follow the maintenance plan.

7 Maintenance and servicing



Observe the safety instructions in chap. Safety, from page 5 on.

Cleaning

To clean the NVV, proceed as follows:

1. Close the supply air opening and the handpiece.
2. Clean the NVV externally with a jet of water.
3. Activate the NVV briefly.

Maintenance plan

Maintenance of the NVV must be carried out as follows:

Interval	Action
After one hour of operation after initial start-up	Check hose screw connections and hose fittings, retighten if necessary.
Before each start-up	Check hose supply connections for damage, permeability and kinks. If necessary, clean and remove kinks or replace.
After every four hours of operation	Check the function of the mist lubricator. Refill oil.
Monthly	Check hose screw connections and hose fittings, retighten if necessary.
	Check the function of the NVV.

Maintenance intervals

The maintenance intervals depend essentially on the operating conditions, the service life and how clean the drive medium is.

Unfiltered compressed air leads to high wear, clogging of the silencer or complete breakdown of the NVV.

Wear criteria

The rotor should be replaced if its length is below

- 109.8 mm for NVV 150,
- 129.7 mm for all other types of NVV.

The vibrator's nosepiece and the vane should be replaced if they show signs of excessive wear.

Replacement of the vane/ the rotor

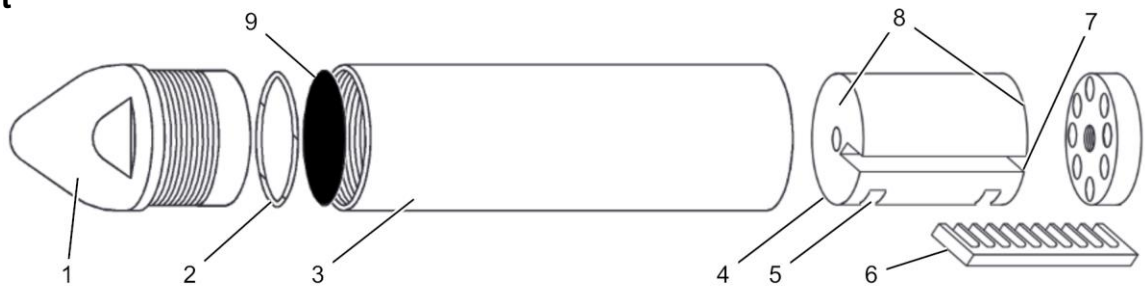

- | | | | |
|---|--------------------------|---|--|
| 1 | Vibrator's nosepiece | 6 | Vane |
| 2 | O-ring | 7 | Slot (hidden) |
| 3 | Housing | 8 | Running face(s) |
| 4 | Rotor | 9 | Front closure plate (only for NVV 150) |
| 5 | Milled slot in the rotor | | |

The replacement of the vane/the rotor has to be carried out as follows:

1. Clamp the housing (3) in a vice, using appropriate chuck jaws (prisms), and unscrew the vibrator's nosepiece (1; right-hand thread).
2. Only for NVV 150:
Remove the front closure plate (9) using a 16 mm extractor (available on request).
3. Remove the housing from the vice and tilt slightly so that the rotor (4) drops into your hand without being damaged.
4. Examine and clean the parts. Criteria for replacement see page 13.
5. Replace the vane (5)/the rotor. Ensure that the vane is easy to move and 0.1 to 0.15 mm shorter than the rotor. Otherwise, it must be shortened so that it does not protrude from the ends of the rotor. The open channels of the vane must point away from the milled slots in the rotor (5).
6. Lightly oil the running faces (8) of the rotor.
7. For assembly, place the housing on a solid surface, put the rotor with vane into the housing. Ensure that the running face without slot points to the nosepiece.
8. Only for NVV 150:
Insert the front closure plate in the housing.
9. Fit a new O-ring (2) onto the nosepiece and screw the nosepiece on the housing.

8 Troubleshooting

Malfunctions and causes

In the case of malfunctions of the NVV proceed as follows:

Malfunction	Possible cause	Corrective action
NVV does not start	Compressed air supply	Check if there is enough pressure at the NVV. Check the pressure control valve.
	Wrong position of the rotor	Briefly tap the vibrator's nosepiece onto a firm surface.
	Vane jammed, too long, missing or incorrectly inserted	Check position and length of the vane (see chap. Maintenance, page 14).
	Hose defective or torn off	Check the hose for damage and for correct fixing, as well in the handpiece (through the inspection window).
NVV has too little power	Line cross-sections	Observe the recommended cross-sections (see chap. Technical data, page 7). Check air pressure and supply lines.
	Wear	Check the vane (see chap. Maintenance, page 14) and the rotor for visible wear. For wear criteria, see page 13. In addition, check the function of the mist lubricator.
Power loss	NVV polluted	Clean the NVV (see chap. Maintenance, page 13).

9 Spare parts and accessories

Ordering of spare parts

Please provide the following details when ordering spare parts:

- type of NVV
- position number of spare part
- required amount

NVV 28 - 100

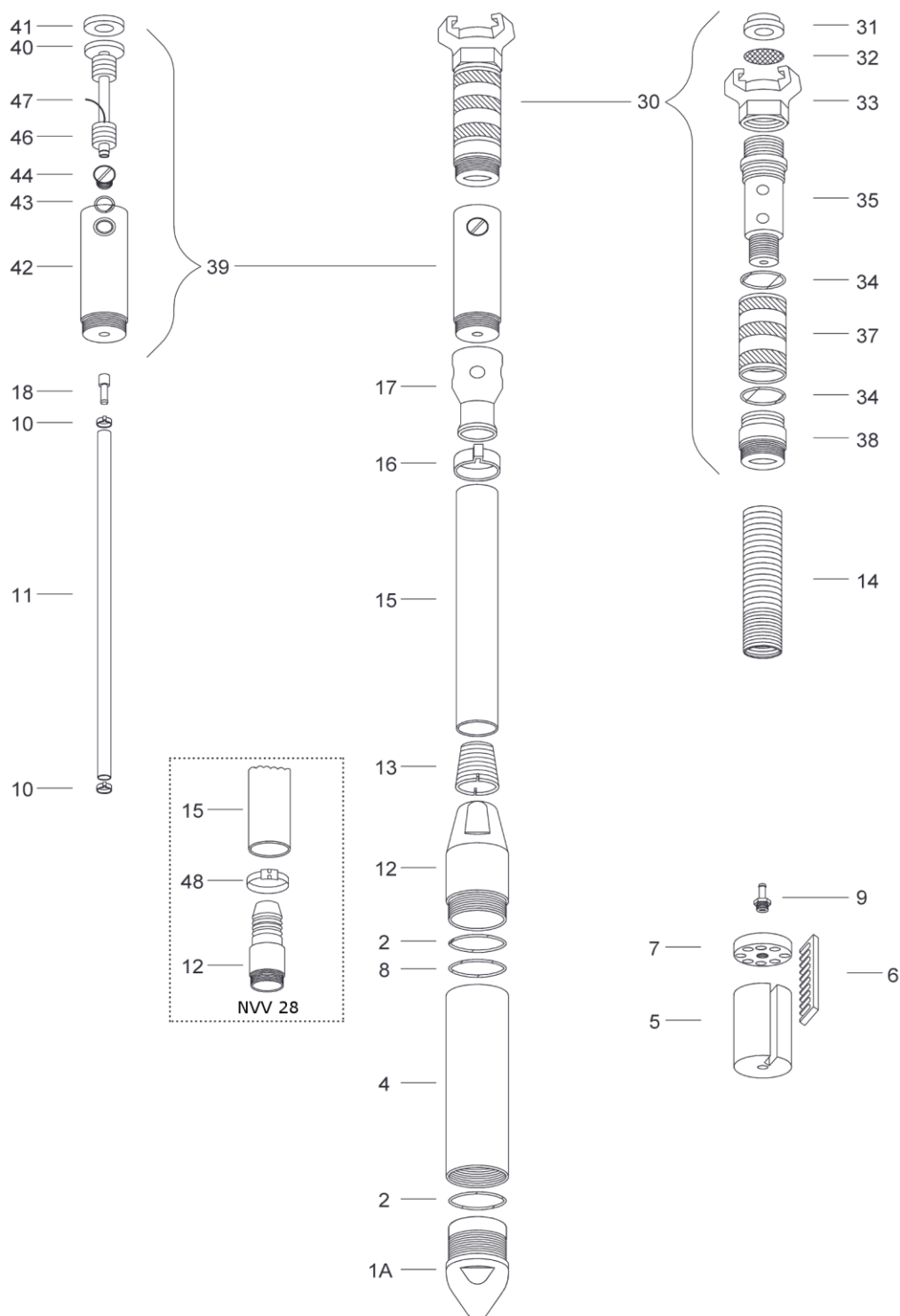

NVV 150

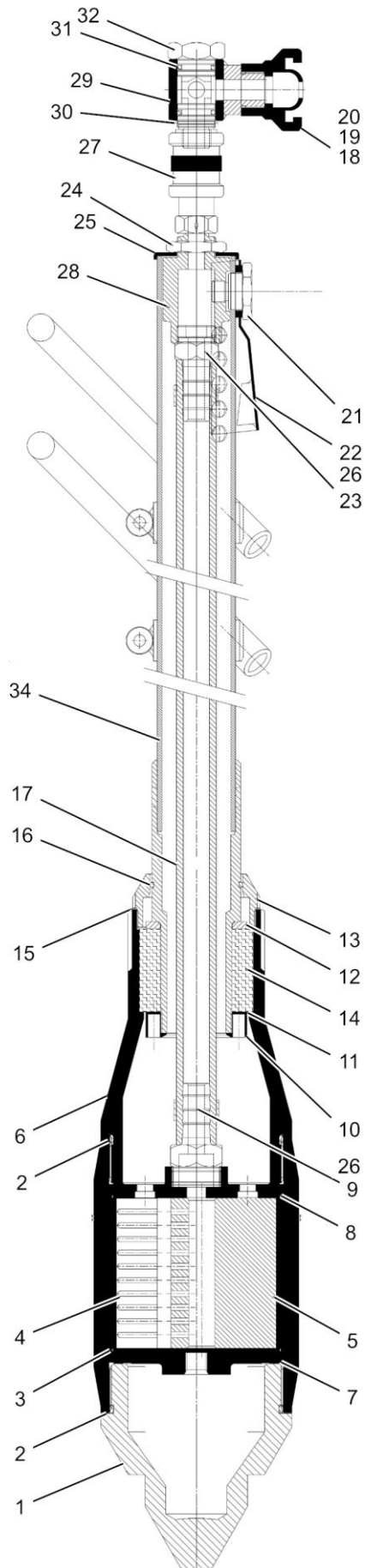

10 Disposal

Prices

	All parts of the NVV must be properly disposed of according to the material specifications. The valid disposal prices of the NVV are available on request.
---	--

Material specifications

All parts of the NVV can be recycled.

Material	Part
Steel	Housing, rotor, vibrator's nosepiece
Aluminium	Handpiece
Plastics	Vane, hose

11 Annex

Declaration of Conformity